

# Design and Dynamic Analysis of Kinetic Energy Recovery System for Toyota Hilux 4X4

Fitsum Tadesse Soramo<sup>1</sup>, Goftila Gudeta Sirata<sup>2</sup> and Iyasu Tafese Jiregna<sup>3</sup>

<sup>1</sup>Department of Mechanical Engineering, Wolaita Sodo University, Ethiopia

<sup>2,3</sup>Faculty of Mechanical Engineering, Jimma University, Ethiopia

**Abstract**—In the present scenario, the energy crisis is one of the main challenges in the real world. The fossil-fuel resources are being depleted at a tremendous rate due to their excessive consumption. This has put forth the widespread assumption that if resources are being used at the current rate, the time is no longer when all our resources will expire. Thus, there is a need to develop technology that saves energy from getting wasted. Traditionally, regenerative braking with the ability to generate energy has been promising, but the amount of energy saved was highly insignificant. A considerable amount of energy, which is generated by the engine, is lost while braking even in case of regenerative braking. The regenerative braking involves direct conversion of the Kinetic energy to Electrical Energy; however, a promising alternative is present while storing the Kinetic Energy of the Vehicle in the form of Mechanical Energy of a rotating cylindrical flywheel. This paper states the advantages of storing the Kinetic Energy of the Vehicle in Mechanical form rather than direct conversion. For the design of this kinetic energy storing device, some calculation has been done for the vehicle at different resistance load, torque, speed, and calculation for selection of the planetary gear, design of flat spiral spring is considered and also using SOLID WORK software some parts of the system are designed. By taking the velocity of the vehicle from 8.34m/sec to 27.8, the kinetic energy loss of the vehicle is increasing with the increase of velocity, but the efficiency of the kinetic energy recovery system will decrease. Braking the vehicle with the velocity of 8.34m/sec has 219KJ of kinetic energy loss, and energy stored by flat spiral spring is 201.4KJ, and the system has efficiency of 91.9% and can save 0.00464L of fuel from 0.005L which will be consumed at 8.34m/sec. But the vehicle moving at 27.8m/sec, the kinetic energy loss is 2434.4KJ, and the stored energy is 201.4KJ, and the kinetic energy recovery system has efficiency of 8.3%. So, using flat spiral spring kinetic energy recovery is useful and recommendable for the vehicle, which has a high stop and goes times.

**Keywords**— Flat spiral spring, Kinetic energy recovery, Planetary gear, Vehicle brake

## I. INTRODUCTION

A kinetic energy recovery system (KERS) is an automobile system which is used to recover the kinetic energy of a moving vehicle during deceleration (braking). The recovered kinetic energy is stored in a reservoir and reused during acceleration. The main aim of the KERS is to extract the kinetic energy during braking and resupply it as additional power to the vehicles. It is a great advantage for the driver [1]. Therefore, the two sources of power for moving vehicle are the engine and the stored kinetic energy. If this kinetic energy of the vehicle is not recovered, it may be wasted during braking since kinetic energy is converted into heat energy and sound energy, which are dissipated to the environment [2–4].

The proper mechanism of KERS helps to store the kinetic energy inside the vehicles before the kinetic energy

is converted to heat and dissipated to the environment. It gives the vehicle additional power to increase the speed when required. There are two main types of KERS systems, i.e., mechanical KERS and electrical KERS. The main difference between these two types of KERS is the way they convert and store energy inside the vehicle. Mechanical KERS uses a rotating flywheel to store the kinetic energy of the vehicle while electrical KERS uses an electromagnet to convert kinetic energy to electrical energy, which slowly transforms into chemical energy and is stored in a battery [5,6]. Battery requires several energy conversions with corresponding efficiency losses. The recent study shows the overall energy conversion efficiency of the batteries is in the range of 31 and 34 percent when energy is reused in the driveline. However, the flywheel stores the kinetic energy and minimizes

various energy conversions [1]. Thus, it provides more than 70 percent of overall energy conversion efficiency, more than twice the efficiency of an electrical KERS system [7].

Additionally, using a battery for storing energy is sometimes at risk. It is susceptible to battery fires and may result in electric shocks. Therefore, using electric KERS is not safe [8].

The Kinetic Energy Recovery System, which is associated with the flywheel, is commonly used in a sports car. The concept of this system is to prevent energy losses in any other form by storing and then reusing this stored energy again when needed. Various Kinetic Energy Recovery Systems are different from each other because of the different storage elements used. The below-discussed KERS system uses Flat Spiral Spring as an energy-storing element and planetary gear system for power transmitting between the spring and the shaft [9,10].

At the time of introduction, many road car manufacturers were beginning to offer hybrid cars that used a similar principle to harvest and reuse energy and so the concept of KERS was one that the public could quickly understand and appreciate [11].

Several vehicle industries started to provide a hybrid vehicle using a similar principle for storing and reusing energy. Therefore, the KERS concept is surprising that it can be easily understandable by scholars. It provides the opportunity of reusing the vehicle kinetic energy. The aim of this study is to design and analysis of the kinetic energy recovery system for Toyota Hilux 4X4.

## II. WORKING PRINCIPLE OF THE KINETIC ENERGY RECOVERY SYSTEM

### A. When the vehicle is accelerating

The sun gear which is mounted on the axle will rotate with the same direction to the axle. The planet gears are meshed with the sun gear and rotate on the ring gear, but the ring gear is idle, means no power is transmitted to the ring gear, and also the drum and the flat spiral springs are idle [12].

### B. When the brake is applied

The sun gear rotates to the direction of the axle. Still, the planetary gear rotates on the carrier pin due to the baking effect the carrier is locked, and the carrier pin, which connects the planet gear and the ring gear, takes advantage and rotate the planet gear because of bearing on the planet and locking key on the carrier side. At this time, the planet transfer the power to the ring gear and the ring gear rotate in the direction of the planet, which is opposite to the

direction of the sun gear. The drum and flat spiral springs are mounted on the ring gear, so the flat spiral spring spins and stores the lost kinetic energy

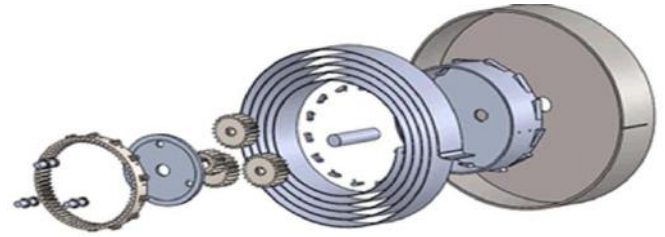

Fig.1: parts of the flat spiral kinetic energy recovery system

### C. One-way clutch (Ratchet) application

The ratchet is used in this system as the guiding to the flat spiral spring. The ratchet on the ring gear is used to resist the rotation of spring to the direction of the vehicle while accelerating.

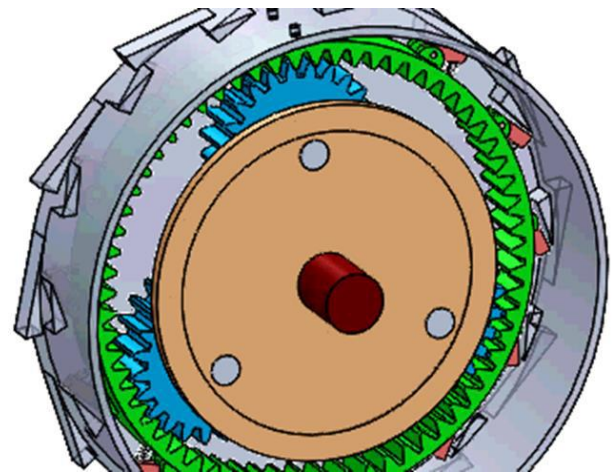

Fig.2: Ratchet system

when the vehicle brakes and the spring starts to wind, the ratchet allow the spring. The next ratchet is the one used to guide the final terminal of the spring to the groove of the housing which is designed to protect the over tightening of the spring which results to failure [13,14].

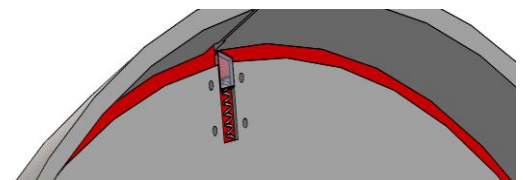

Fig.3: The groove on the drum

### III. DESIGN OF SPRING

In this section,, the design of the flat spring, which is the storing device for the lost kinetic energy of the vehicle, is presented. As shown in Figure 4, a flat spring is a long , thin strip of the elastic material wound like a spiral. These springs are often used in watches and gramophones, and so on. When the outer or inner end of this type of spring is wound up in such a manner that there is a tendency to increase the number of spring spirals, the energy of the strain is stored in its spirals. This energy is used in any useful manner as the spirals slowly open out. The inner end of the spring is usually clamped into an arbor while the outer end may be fixed or tightened. Since the curvature radius of each spiral decreases when the spring is wound up, therefore, the spring material is in a pure bending state [15].

#### Material Specifications

- Stainless steel wire, hardening 17-7, NiCr,A2E6
- Young`s modulus (E) = 208Gpa
- Density (ρ) = 8.03g/cc
- Maximum service temp = 3230C
- Factor of safety =2
- Tensile strength (σ) = 1800Mpa
- Assumption for design purpose of spring
- Width (b) = 44mm
- Thickness (t) = 1.5mm
- Internal diameter (d) = 183 mm
- External diameter (D) = 310mm



Fig.4: Flat spiral spring

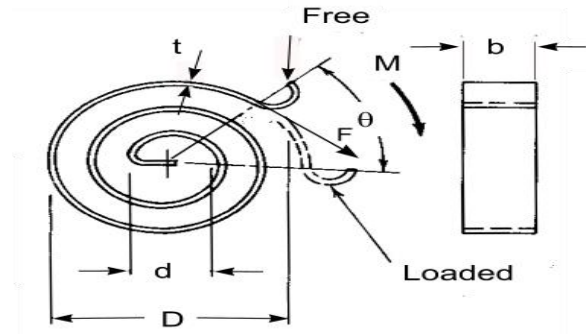

Fig.5: The dimension of flat spiral spring

Let W= Force applied at the outer end A of the spring, y = Distance of center of gravity from the outer end of the spring A,

$$y = D/2$$

$$Z = \frac{1}{y} = \frac{b_t^3}{12 \times t/2} = \frac{b_t^2}{6} \text{-----(1)}$$

$$Z = \frac{44 \times 1.5^2}{6} = 16.5 \text{mm}^3$$

$$I = \frac{b.t^3}{12} \text{-----(2)}$$

Where, l = the strip length forming the spring, b = spring width(mm) t = spring thickness (mm)

When the force W pulls the end A of the spring, then the bending moment on the spring at a distance y is given by:

$$M = W \times y \text{-----(3)}$$

The largest bending moment occurs at B in the spring, which is at maximum distance from the application of W.

Bending moment at B,

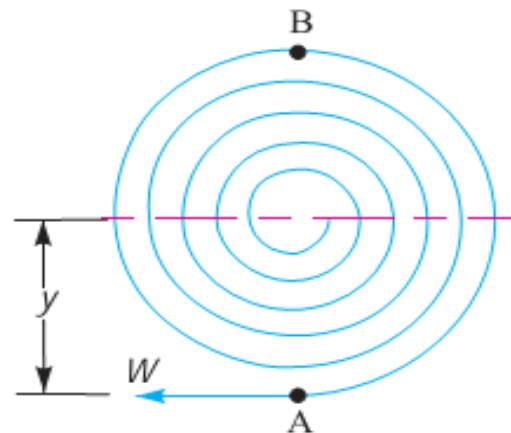

Figure 6 bending moment occurrence point

$$M_B = M_{max} = W \times 2y = 2W.y = 2M \text{----(4)}$$

Maximum induced bending stress in the spring material,

$$\sigma_b = \frac{M_{max}}{Z} = \frac{2W \times y}{b_t^2 / 6} = \frac{12.W.Y}{b_t^2} = \frac{12M}{b_t^2} \text{---(5)}$$

Assuming that both ends of the spring are clamped, the angular deflection (in radian) of the spring is given by Equation (6)

$$\theta = \frac{M.l}{E.I} = \frac{12M.l}{Eb_t^3} \text{---(6)}$$

$$= \frac{12 \times 455374.5l}{208 \times 10^3 \times 44 \times (1.5)^3} = 0.18l$$

$$\delta = \theta \times y = \frac{M.l.y}{E.I} \text{---(7)}$$

The strain energy stored in the spring

$$ES = \frac{\sigma^2}{24E} \times b.t.l = \frac{\sigma^2}{24E} \times volume \text{---(8)}$$

$$ES = \frac{(55196.91)^2}{24 \times 208000} \times 44.1.5.l$$

$$E_s = 40280.87l$$

Where

D = Outside diameter of spring (m)

M = Moment/torque on spring = F.D / 2(Nm)

L = Length of strip (m)

G = Modulus of Rigidity (N/m<sup>2</sup>)

d = Inside diameter of spring (m)

n = Number of turns of spring

E = Young's Modulus (N/m<sup>2</sup>)

θ = Deflection (radians)

y = distance from neutral axis to outer fiber of wire/strip = D / 2 (m)

#### IV. RESULTS AND DISCUSSION

This section presents the results obtained from the numerical analysis of flat spiral spring, and SOLIDWORK software was used for the numerical analysis of drum, carrier, carrier pin then the results obtained from the numerical and analytical results are compared.

#### a) Energy absorbed by the brake

The energy absorbed by a brake depends on the type of motion of the moving body. The motion of a body may be either a pure translation or a pure rotation or a combination of translation and rotation. Kinetic energy is the energy corresponding to these motions.

Let us consider these motions as follows:

Consider a body of mass (m) moving at a velocity U m / s when the body's motion is a pure translation. By applying the brake let its velocity be reduced to V m / s. Thus, the change in the kinetic energy of the translating body or the kinetic energy translation, on equation (7)

$$KE = (1/2) m [(u)^2 - (v)^2]$$

Gross vehicle mass = 3150 Kg from car specification

Let assume vehicle speed ranges from (0-100Km/hr)

The brake must absorb that energy. When the vehicle is stopped after applying the brakes, then the final velocity (V) = 0, and from equation (3.38).

$$KE = (1/2) m (U)^2$$

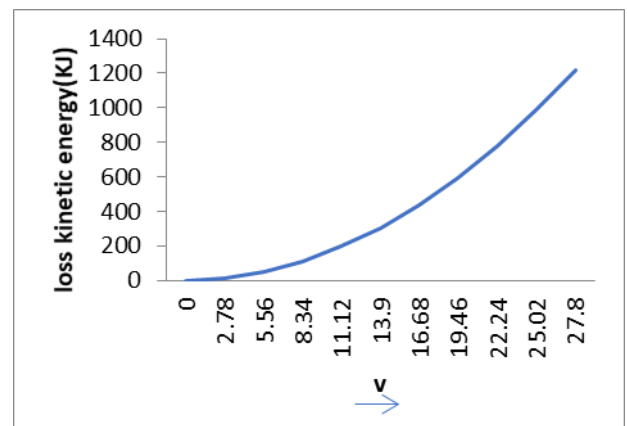

Fig.7: Kinetic energy when final velocity equals zero

For a vehicle moving with a velocity of 27.78m/sec, the kinetic energy loss of Toyota Hilux 4x4 is about 2430.74KJ, but the calorific value of Diesel is approximately 44800 kJ/kg [3]. This means 2430.74/44800 = 0.0543 kg or 54.3 gms of Diesel equivalent energy was lost as heat. While for some, these might be insignificant values; however, they become huge numbers over the lifetime of the car. Therefore, the regenerative braking feature is essential to evolve for having sustainable transport.

#### Energy stored on Flat spiral spring

The spiral spring is subjected to a torque applied in such a way that the relative shaft–housing rotation causes bending

of the turns the spiral strip. It is assumed that the spring housing is fixed using a driver-controlled lever and the inner shaft is loaded by a torque (during vehicle braking) about the spring axis, the spiral spring will thus deform and stores the kinetic energy of the vehicle as elastic potential energy. This stored energy can then be utilized to provide an instant boost to the vehicle.

Carrier is one part of the kinetic energy recovery system which is design to hold the carrier pin with the planet gear.

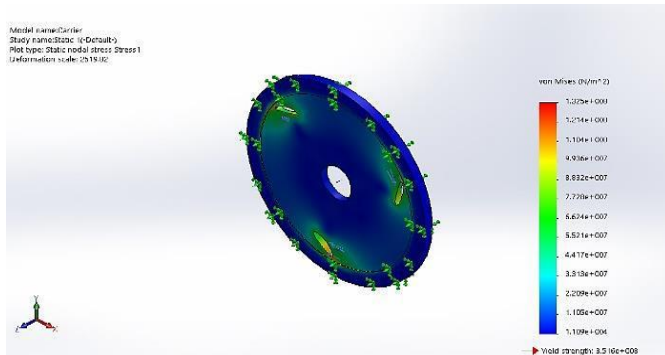

Fig.8: Carrier-Static 1-Stress-Stress1

Figure 8 shows the simulation result of von mises stress for a carrier, which has minimum value  $1.109 \times 10^4$  N/m<sup>2</sup> and maximum value  $1.325 \times 10^8$  N/m<sup>2</sup> and selected material yield strength is  $3.516 \times 10^8$  N/m<sup>2</sup>. This shows the carrier is safe for application because yield strength is higher than the von mises stress.

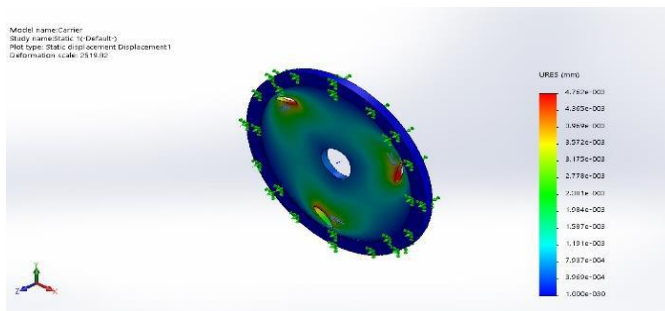

Fig.9: Carrier-Static 1-Displacement-Displacement

The deformation scale is 2519.82, which indicates the carrier is too far to deform with the applied torque.

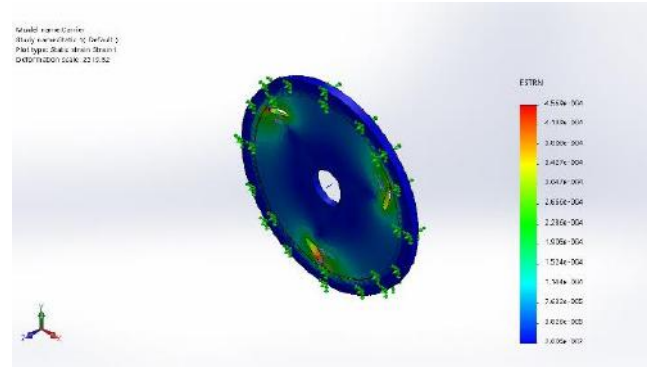

Fig.10: Carrier-Static 1-Strain-Strain1

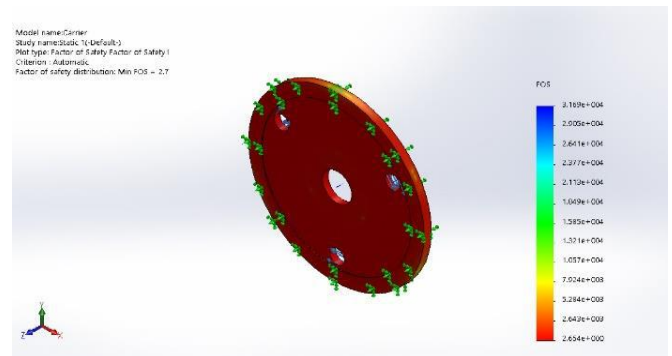

Fig.11: Carrier-Static 1-Factor of Safety-Factor of Safety1

Carrier pin (shaft) is used to connect the carrier (arm) with the planet gears.

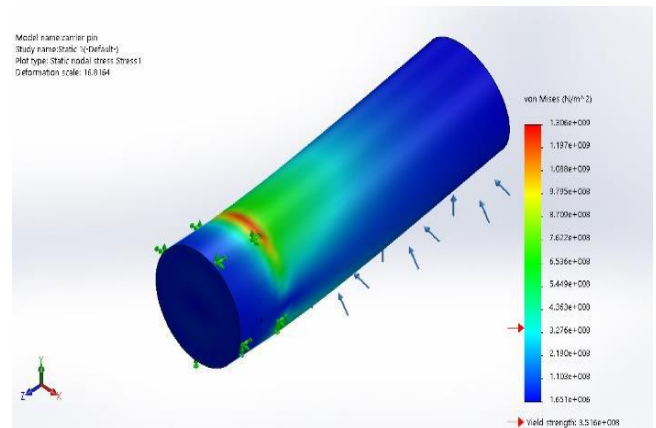

Fig.12: Carrier pin-Static 1-Stress-Stress1

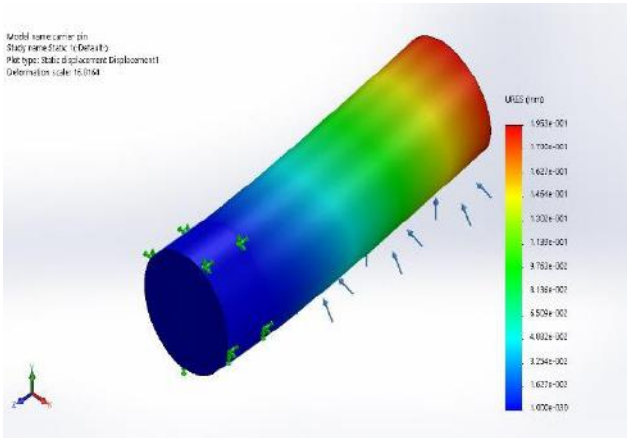

Fig.13: Carrier pin-Static 1-Displacement-Displacement1

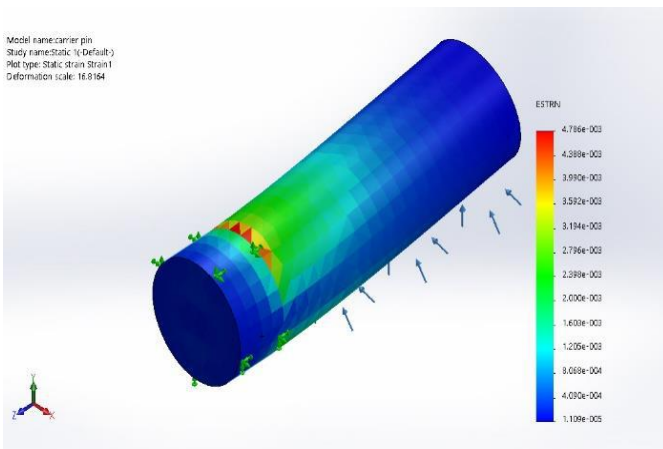

Fig.14: Carrier pin-Static 1-Strain-Strain1

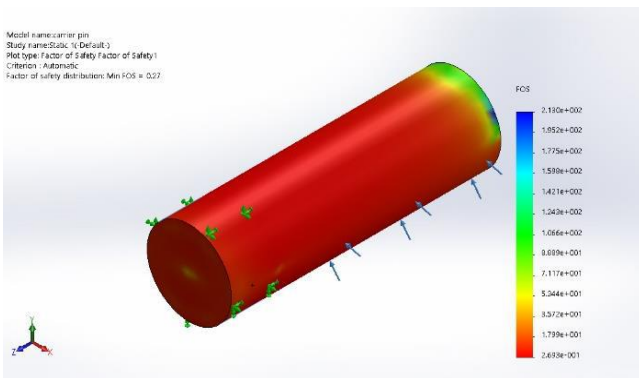

Fig.15: Carrier pin-Static 1-Factor of Safety-Factor of Safety1

The one-way clutch is a ratcheting device onto which the drum is mounted. The one-way clutch ensures that the motion or energy is not transmitted to the drum during idling or braking.

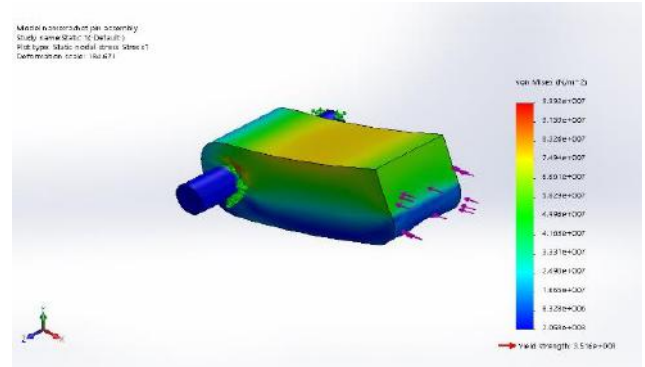

Fig.16: Ratchet pin assembly-Static 1-Stress-Stress1

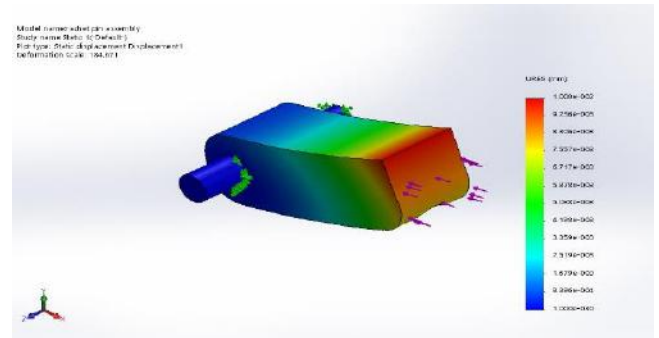

Fig.17: Ratchet pin assembly-Static 1-Displacement-Displacement1

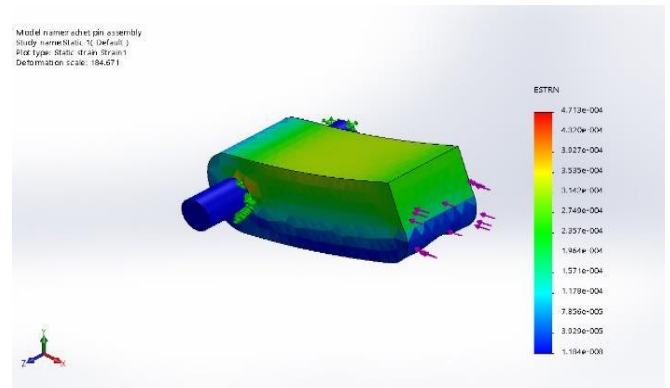

Fig.18: Ratchet pin assembly-Static 1-Strain-Strain1

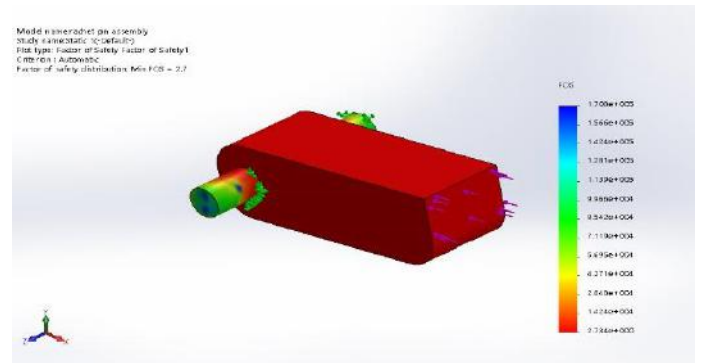

Fig.19: Ratchet pin assembly-Static 1-Factor of Safety-Factor of Safety1

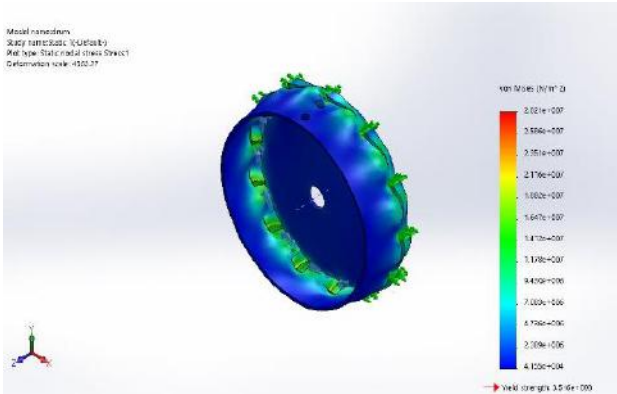

Fig.20: Drum-Static 1-Stress-Stress1

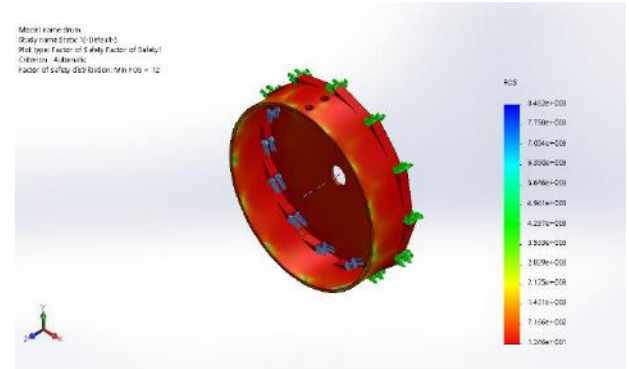

Fig.23: Drum-Static 1-Factor of Safety-Factor of Safety1

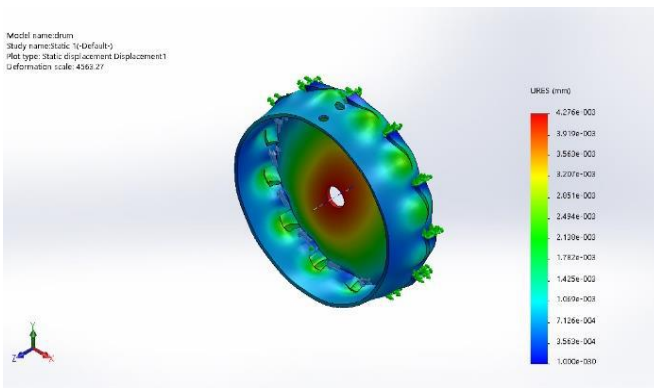

Fig.21: Drum-Static 1-Displacement-Displacement1

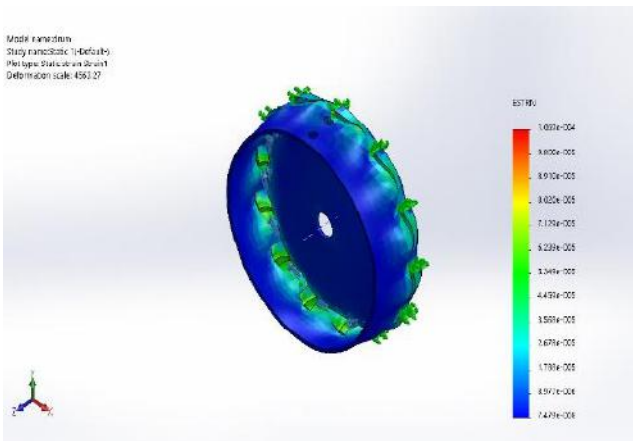

Fig.22: Drum-Static 1-Strain-Strain1

### V. CONCLUSION

A flat spiral spring-based mechanical regenerative braking can use the flat spiral spring to slow the vehicle while storing energy as well as accelerate the vehicle while releasing energy from the spring. This concept was designed to be placed on the planetary gear assembly of the vehicle.

The axle only rotates in one direction while the vehicle is in forwarding motion; thus, the design allows for this single direction of motion during both the regeneration mode and assist mode. In most strain devices, the deformation and relaxation cycle involves a reversal in direction. The flat spiral spring regenerative system mechanism is intended to function only when the vehicle is moving forward; thus, it must account for the reversal of the storage element.

The regenerative braking and assist modes should only be active while the car is accelerating or decelerating; when the vehicle is at a constant speed, the device should be inactive. Ideally, the device should produce minimal effects on the vehicle while not in use. Thus, this device must engage and disengage from the axle.

By taking the velocity of the vehicle from 8.34m/sec to 27.8, the kinetic energy loss of the vehicle is increasing with the increase of velocity, but the efficiency of the kinetic energy recovery system will decrease. Braking the vehicle with a velocity of 8.34m/sec has 219KJ of kinetic energy loss, and energy stored by flat spiral spring is 201.4KJ, and the system is 91.9% and can save 0.00464L of fuel from 0.005L which will be consumed at 8.34m/sec. But the vehicle moving at 27.8m/sec, the kinetic energy loss is 2434.4KJ, and the stored energy is 201.4KJ, and the kinetic energy recovery system is 8.3%. So using flat spiral spring kinetic energy recovery is useful and recommendable for a vehicle that has high stop and goes times.

In the coming days, the spring-based regenerative system will gain more attention with the advancement in spring design and spring material. The vehicle with the start-stop cycle of driving will be affected the most with the introduction of this technology. The kinetic energy recovery using a flat spiral spring is good even though it needs more improvement and electronic integration into the system.

### REFERENCES

- [1] S. Holt. Formula for success – Kers and DRS. BBC Sport 2012.
- [2] Carlin S. An analysis of kinetic energy recovery systems and their potential for contemporary internal combustion engine powered vehicles 2015.
- [3] Khavdu R. Regenerative Braking System is Emerging Technology to Recover Waste Energy. International Journal of Engineering Development and Research (\copyright 2015 IJEDR| Volume 3, Issue 4| ISSN: 2321-9939 2015.
- [4] Abhale Y, Nigam P. Review on regenerative braking methodology in electric vehicle. International Journal of Advanced Research in Electrical, Electronics and Instrumentation Engineering 2015;4:6380–6386.
- [5] Śliwiński C. Kinetic energy recovery systems in motor vehicles. Scientific Conference on Automotive Vehicles and Combustion Engines (KONMOT 2016) IOP Publishing IOP Conf. Series: Materials Science and Engineering148, vol. 12056, 2016.
- [6] Perrotta D, Ribeiro B, Rossetti RJ, Afonso JL. On the potential of regenerative braking of electric buses as a function of their itinerary. Procedia-Social and Behavioral Sciences 2012;54:1156–1167.
- [7] Vishwakarma D, Chaurasia S. Regenerative Braking System. IMPERIAL INTERNATIONAL JOURNAL OF ECO-FRIENDLY TECHNOLOGIES (IJJET) 2016;1:30–33.
- [8] Halley M. Kinetic energy recovery systems in formula 1. ATZautotechnology 2008;8:58–61.
- [9] Behera DN, Chattopadhyay S, Banerjee S, Swain SS. “i-Eloop Regenerative Braking System”IJSET-International Journal of Innovative Science. Engineering & Technology 2016;3.
- [10] Godfrey AJ, Sankaranarayanan V. A new electric braking system with energy regeneration for a BLDC motor driven electric vehicle. Engineering Science and Technology, an International Journal 2018;21:704–713.
- [11] Gupta P, Kumar A, Deb S. Shayan.(2014). Regenerative Braking Systems (RBS)(Future of Braking Systems). International Journal of Mechanical And Production Engineering n.d.;2:75–78.
- [12] HOLEŠOVSKÝ J. Analýza a porovnání marketingu Formule 1 a NASCARu. PhD Thesis. Masaryk University, Faculty of Sports Studies, 2018.
- [13] Menon SS, Sooraj M, Mohan S, Disney R, Sukumaran S. Design and analysis of kinetic energy recovery system in bicycles. IJRSET, ISSN 2013:2319–8753.
- [14] Kumar EA. Hydraulic regenerative braking system. Int J Sci Eng Res 2012;3:1–12.
- [15] Khurmi R, Gupta J. A textbook of machine design, first multicolour edition. Eurasia Publishing House Ltd 2005;7361:509–556.