

Different Zone Case Study of Multistory Building

Shivam Barpete¹, Mohit Kumar Prajapati²

¹M.Tech. Research Scholar School of Engineering and Technology, Vikram University Ujjain, MP, India

²Faculty Civil Engineering Department, School of Engineering and Technology, Vikram University Ujjain, MP, India

Received: 07 Aug 2025,

Received in revised form: 02 Sep 2025,

Accepted: 05 Sep 2025,

Available online: 10 Sep 2025

©2025 The Author(s). Published by AI
Publication. This is an open-access article
under the CC BY license

Keywords— *structural configurations,
seismic analysis, Equivalent Lateral,
Response Spectrum Method.*

Abstract— *The analysis of multistory buildings under different zoning conditions is essential for ensuring structural safety, serviceability, and compliance with building codes. In this case study, a comparative evaluation of a multistory reinforced concrete building is carried out across different seismic and wind load zones. The study focuses on parameters such as base shear, lateral displacement, story drift, and overall stability of the structure when subjected to varying environmental and seismic intensities. Structural modeling and analysis are conducted using standard design codes (such as IS 1893 for seismic loads and IS 875 for wind loads), and the results are compared zone-wise to highlight critical differences in structural behavior.*

I. INTRODUCTION

Dynamic actions are caused on buildings by both wind and earthquakes. But, design for wind forces and for earthquake effects are distinctly different. The intuitive philosophy of structural design uses force as the basis, which is consistent in wind design, where in the building is subjected to a pressure on its exposed surface area; this is force type loading. However, in earthquake design, the building is subjected to random motion of the ground at its base, which induces inertia forces in the building that in turn cause stresses; this is displacement-type loading. Another way of expressing this difference is through the load deformation curve of the building – the demand on the building is force(i.e., vertical axis) in force-type loading imposed by wind pressure, and displacement(i.e., horizontal axis) in displacement type loading imposed by earthquake shaking. Wind force on the building has a non-zero mean component superposed with a relatively small oscillating component. Thus, under wind forces, the building may experience small fluctuations in the stress field, but reversal of stresses occurs only when the direction of wind reverses, which happens only over a large duration of time. On the other hand, the motion of the ground during the earthquake is cyclic about the neutral position of the structure. Thus, the stresses in the

building due to seismic actions undergo many complete reversals and that to over the small duration of earthquake.

II. NEED FOR DAMPING DEVICES IN STRUCTURES

Current trends in construction industry demands taller and lighter structures, which are also more flexible and having quite low damping value. Out of the several techniques available for vibration control, concept of using energy dissipation devices is an effective one. As structure tends to be more sensitive to seismic and wind excited vibrations, this has led the engineers to turn up the implementation of damping devices in structures in order to increase the damping and thus decrease the uncontrolled vibrations and accelerations which cause human discomfort. The selection of a particular type of vibration control device is governed by a number of factors which include efficiency, compactness and weight, capital cost, operating cost, maintenance requirements and safety.

Energy dissipation by means of damping is one of many different methods that have been proposed for allowing a structure to achieve optimal performance when it is subjected to seismic, wind storm or other types of vibration disturbances. The level of damping in convectional structures is very low, and hence the amount of energy

dissipated during transient disturbances is also very low as the energy dissipation occurs by means of inelastic deformation of the structural elements. Therefore, most of the energy dissipated is absorbed by the structure itself through localized damage. The concept of add-on dampers within a structure assumes that sum of the energy input to the structure from a transient disturbances will be absorbed, not by the structure itself, but rather by supplemental damping elements. An idealized supplemental damper would be of a form such that the force being produced by the damper is of such a magnitude occurs at such a time that the damper forces do not increase overall stress in the structures. Properly implemented and installed ideal dampers should be able to simultaneously reduce both stress and deflection in the structure.

III. RCC FRAME STRUCTURES

A RCC circled structure is a social gathering of areas, bars, fragments, and foundations are interconnected to one another to form a unit. The pile moves in a particular manner to the construction, occurs from the lumps to the columns, from the beams and a while later to the lower sections (slabs), finally to the foundation(from it passes to earth core). The floor area of a R.C.C restricted construction building is 10 to 12 percent more than that of a pile bearing walled developing. Strong advancement is possible with R.C.C enclosed constructions and they can go against vibrations, wind loads, shudder and dazes more effectively than load-bearing walled structures. The speed of advancement for RCC surrounded constructions is progressively quick as compared to load bearing structure.

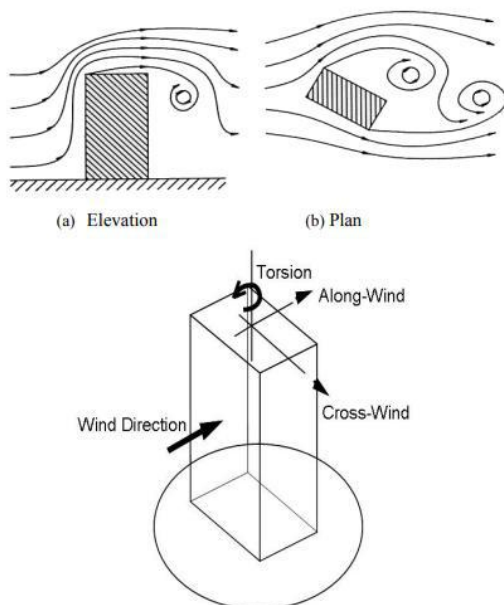

Fig 1: Wind Response Directions.

Many researches and studies have been done in order to mitigate excitations and improve the performance of tall building against wind loads. An extremely important and effective design approach among these methods is aerodynamic modifications, including, modifications of buildings corner geometry and its cross-sectional shape. Tall buildings are gigantic projects demanding incredible logistics and management, and require enormous financial investment. A careful coordination of the structural elements and the shape of a building which minimize the lateral displacement, may offer considerable savings. Nowadays, the challenge of designing an efficient tall building has considerable changed.

The conventional approach to tall building design in the past was to limit the forms of the building to a rectangular shape mostly, but today, much more complicated building geometries could be utilized. It has been concluded that the principal reasons of failure may be attributed to soft stories, floating columns, mass irregularities, poor quality of construction materials and faulty construction practices, inconsistent wind force response, soil and foundation, effect of pounding of adjacent structures.

All over world, there is high demand for construction of tall buildings due to increasing urbanization and spiraling population, and wind loads have the potential for causing the greatest damages to tall structures. Since wind forces are random in nature, the engineering tools need to be sharpened for analyzing structures under the action of these forces.

GOALS OF EARTHQUAKE RESISTANT STRUCTURES

It is economically not feasible for ordinary buildings to be designed as absolute earthquake proof. However, the goals for Earthquake Resistant Design (EQRD) are shown below. Serviceability level Earthquake

- Frequent and minor earthquakes
- Building should not be damaged and continue to remain in service
- Expected ten times during the life of building
- Damageability level Earthquake
- Occasional moderate earthquakes
- No structural damage is expected.
- Non structural damage should not lead to any loss of life.
- Expected once or twice during the life of building. Safety level Earthquake
- Rare major earthquakes
- Building should not collapse

- Non-structural & structural damage should not lead to any loss of life.

IV. PROPOSED METHODOLOGY FINITE ELEMENT METHOD (FEM)

Finite Element Method (FEM) is a computational technique widely used in structural analysis to model and evaluate complex structures. FEM allows engineers to simulate how structures will respond to different loading conditions, including stress, strain, and displacement.

UNDERSTANDING THE BASICS OF FEM

Finite Element Method (FEM) is a numerical approach that divides a complex structure into smaller, simpler parts called finite elements. A set of equations governs these elements based on physical laws. By solving these equations, FEM helps engineers approximate the behavior of the entire structure. The goal is to predict how forces, pressures, and displacements affect it.

One of FEM's primary strengths is its ability to handle complex geometries, materials, and boundary conditions, making it a versatile tool for a wide range of engineering applications. FEM works by creating a finite element mesh, a network of smaller parts that helps simulate and analyze local effects and their impact on the overall structure.

THE ROLE OF FEM IN STRUCTURAL ANALYSIS

FEM plays a vital role in structural analysis by transforming a continuous structure into a set of discrete elements, allowing for the detailed study of each part. Engineers use FEM to predict how a structure will respond to various load conditions, whether static or dynamic forces.

The image below showcases the practical application of FEM, with a meshed component analyzed for stress distribution, visualized through color-coded stress gradients.

Principle of Minimum Potential Energy

At the core of FEM is the Principle of Minimum Potential Energy. This principle states that a structure is in equilibrium when its total potential energy is minimized. When a structure deforms due to applied loads, it stores potential energy.

FEM applies this principle by minimizing the stored energy in each finite element, which allows engineers to predict how the structure will behave under various loading conditions.

The diagram below illustrates the relationship between work, force, and displacement in mechanical systems, which is fundamental to understanding energy principles in FEM.

Discretization in FEM

Discretization is a fundamental step in FEM, where the continuous system (structure) is divided into finite elements. Each element has its own geometry, material properties, and relationships with neighboring elements. By discretizing the structure, engineers transform the problem of analyzing the entire system into solving a set of smaller, interconnected problems.

The accuracy of FEM depends heavily on the type and size of the finite elements used. Engineers must carefully select element shapes (e.g., triangles, tetrahedrons) and sizes to balance computational efficiency with the precision of results. Proper meshing is crucial for capturing the correct behavior of the structure and minimizing errors in simulation.

DIFFERENT TYPES OF FEM

Linear FEM

Linear FEM assumes that the relationship between applied loads and resulting displacements is proportional, meaning the structure's response is elastic and follows Hooke's Law. This method is commonly used when the structure's behavior remains within the elastic range, where stress and strain are directly proportional.

Engineers often apply linear FEM to simpler problems, such as beams, trusses, and frames, in fields like civil, mechanical, and aerospace engineering. Its advantage lies in the simplicity and speed of computation, making it efficient for many practical applications. However, linear FEM is limited when dealing with complex phenomena such as plasticity, large deformations, or material failure.

Non-linear FEM

When structures undergo large deformations, or when materials exhibit non-linear stress-strain behavior, non-linear FEM is required. This method is essential for accurately modeling real-world situations where the assumptions of linear FEM no longer apply, such as in crash simulations, buckling analysis, or the study of plastic deformation.

Non-linear FEM, though more computationally intensive, provides a more realistic assessment of structural behavior under extreme conditions. Engineers must account for factors like material plasticity, creep, and contact between parts to ensure accurate results.

Despite the increased complexity, non-linear FEM is critical for designing safer and more reliable structures in fields such as automotive safety and high-performance engineering.

THE PROCESS OF FEM IN STRUCTURAL ANALYSIS

Pre-processing Stage

During the pre-processing stage, engineers define the structure's geometry, assign material properties, and generate the finite element mesh. This involves converting the physical model of the structure into a mathematical one that can be solved using FEM. Engineers also apply boundary conditions and loads to simulate real-world operating conditions.

At this stage, engineers may refine the mesh to improve the accuracy of the analysis, especially in areas where stress concentrations are expected. This step helps ensure that the FEM results are reliable and converge to an accurate solution.

V. RESULT AND SIMULATION

The analysis of a multistory building in different zones was carried out using STAAD.Pro to study the effect of seismic and wind loads on structural behavior. A standard RC frame building model was created with assigned dead loads, live loads, and lateral loads as per IS codes. Zone-wise variations were applied by changing seismic parameters like zone factor and importance factor. The software generated results such as bending moment, shear force, axial force, base shear, and story displacement for each zone. This highlights the need for stronger sections, lateral load resisting elements like shear walls, and ductile detailing in higher zones to ensure safety and stability of the multistory building.

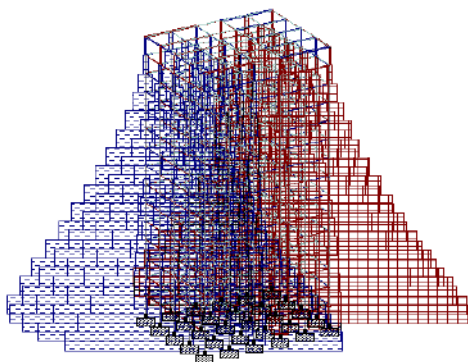

Fig 2: Axial Force impact.

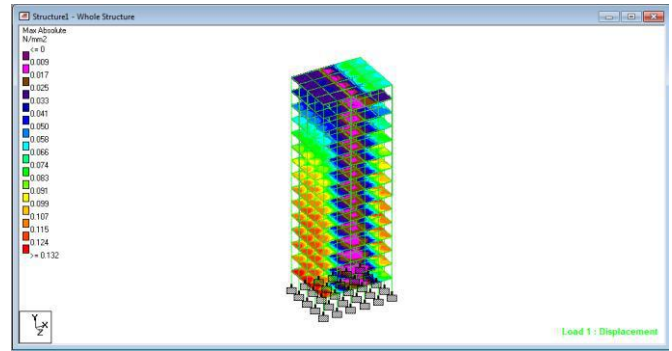

Fig 3: Displacement occur.

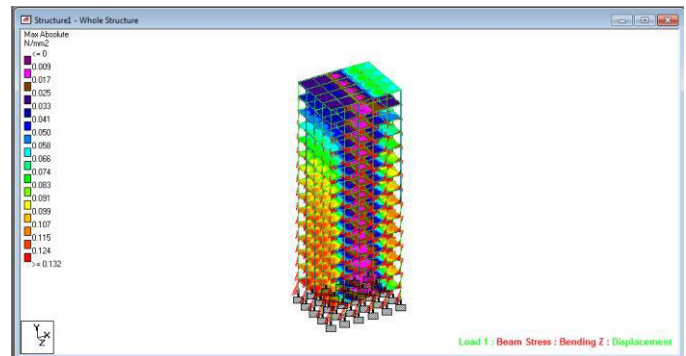

Fig 4: Shear bending and Displacement.

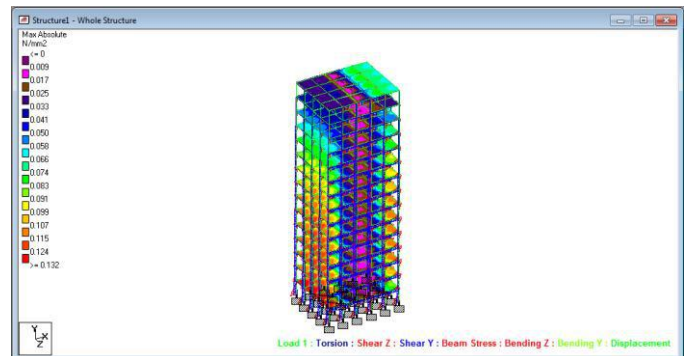

Fig 5: Torsion.

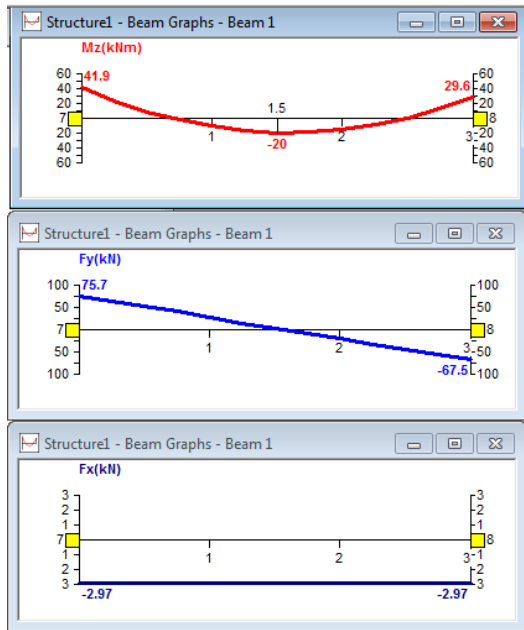

Fig 6: Bending Moment Curve initial case.

1. Bending Moment Diagram (Mz in kNm) – Top Graph

- The red curve represents the bending moment distribution along the span of the beam.
- Left end moment: 41.9 kNm
- Right end moment: 29.6 kNm
- Maximum sagging moment: -20 kNm (at midspan, downward concave).
- The shape is parabolic, which is typical for a beam under uniform loading.
- Positive values at the supports indicate hogging moments (beam tends to bend upwards at supports), while negative values at midspan indicate sagging moments (beam bends downwards).

2. Shear Force Diagram (Fy in kN) – Middle Graph

- The blue line shows shear force variation along the beam.
- Left support shear: +75.7 kN (upward reaction).
- Right support shear: -67.5 kN (downward reaction).
- The shear force decreases linearly across the span, which corresponds to a uniformly distributed load (UDL) acting on the beam.
- The slope of the line = load intensity.
- Positive on the left side and negative on the right indicates equilibrium of forces.

3. Axial Force Diagram (Fx in kN) – Bottom Graph

- The blue straight line shows axial (horizontal) force in the beam.
- Value = -2.97 kN along the span.
- The negative sign indicates compression in the beam.
- Since it is constant, the axial force is uniformly applied (e.g., due to frame action or small horizontal load).
- In normal beams under vertical loading, axial force is usually negligible unless part of a frame structure.

Interpretation

- This beam is simply supported or part of a continuous frame, subjected mainly to a uniformly distributed vertical load.
- The bending moment diagram (parabolic), shear force diagram (linear), and small axial force confirm typical beam behavior under UDL.
- End moments suggest the beam is not simply supported, but likely fixed or part of a continuous beam, since a simply supported beam would have zero end moments.

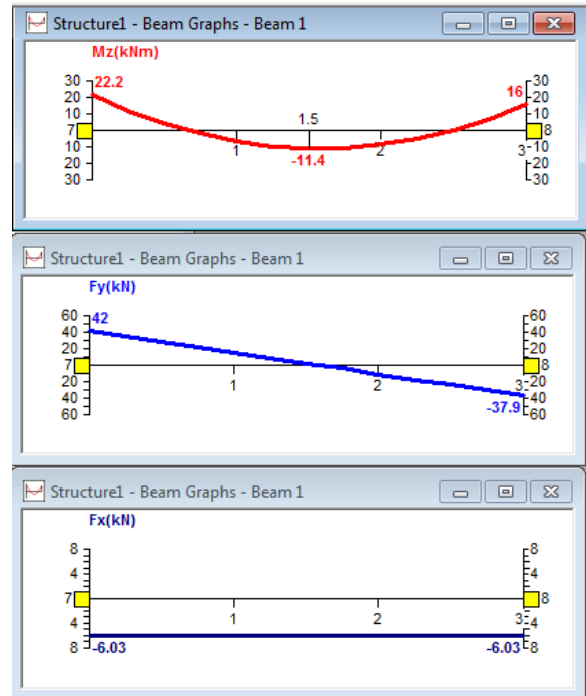

Fig 7: Bending Moment Curve Final case.

Showing the bending moment, shear force, and axial force diagrams. Let's carefully interpret each one:

1. Bending Moment Diagram (Mz in kNm) – Top Graph

- The red curve shows bending moment along the beam span.
- Left end moment: 22.2 kNm
- Right end moment: 16 kNm
- Maximum sagging moment: -11.4 kNm (at midspan).
- The parabolic curve indicates a uniformly distributed load (UDL).
- Positive values at supports → hogging moment (beam bends upward at supports).
- Negative value at midspan → sagging moment (beam bends downward at center).

Observation: The moments are smaller compared to the first image you uploaded (less load intensity or smaller span).

2. Shear Force Diagram (Fy in kN) – Middle Graph

- The blue straight line shows shear force.
- Left support shear: +42 kN (upward reaction).
- Right support shear: -37.9 kN (downward reaction).
- The shear decreases linearly, confirming a uniformly distributed vertical load.
- The slope of this line = intensity of UDL applied.

Observation: Reactions are balanced, and the smaller magnitude compared to your earlier beam indicates a lighter load.

3. Axial Force Diagram (Fx in kN) – Bottom Graph

- The blue line is constant across the span.
- Value: -6.03 kN (compression in the beam).
- Negative sign = compressive axial load, constant along length.
- This usually occurs when the beam is part of a frame structure, where horizontal loads or frame action induce axial force.

Overall Interpretation

- The beam is partially fixed or continuous, not simply supported (since there are non-zero end moments).
- The load on this beam is uniformly distributed, but with lower intensity compared to the first case you showed (because bending moment, shear, and axial values are smaller).
- The structural behavior is typical:
 - Parabolic bending moment (UDL effect).
 - Linear shear force.

- Constant axial force (frame effect).

VI. CONCLUSION

The comparative analysis of beam behavior under different loading conditions and support restraints highlights the significant influence of load intensity and boundary conditions on structural performance. The bending moment, shear force, and axial force diagrams confirm that beams subjected to higher uniformly distributed loads experience larger end moments, shear reactions, and mid-span deflections. In contrast, beams under lighter loads display reduced stresses and more favorable moment distribution. The presence of axial forces further indicates the effect of frame action in multistory structures, emphasizing the need for accurate modeling of load paths and support connections. Overall, the study demonstrates the necessity of zone-wise structural analysis to ensure safety, economy, and serviceability in multistory building design.

Future Scope

The present study can be extended by incorporating nonlinear analysis to capture real-life material behavior under ultimate loading conditions. Future research may focus on the dynamic response of multistory buildings under seismic and wind loads across different zones, as well as the effectiveness of advanced lateral load resisting systems such as shear walls, bracings, and dampers. Integration of Building Information Modeling (BIM) and performance-based design approaches can further enhance precision in analysis and optimization of resources. Moreover, sustainable materials and smart monitoring systems can be explored to improve structural resilience and adaptability to future loading scenarios in high-rise construction.

REFERENCES

- [1] Berwart, S., Estrella, X., Montaña, J., Santa-María, H., Almazán, J. L., & Guindos, P. (2022). A simplified approach to assess the technical prefeasibility of multistory wood-frame buildings in high seismic zones. *Engineering Structures*, 257, 114035.
- [2] Tutu, K. A., Odei, D. A., Baniba, P., & Owusu, M. (2022). Concrete quality issues in multistory building construction in Ghana: Cases from Kumasi metropolis. *Case Studies in Construction Materials*, 17, e01425.
- [3] Lu, R., Xia, D., Ma, X., Zhao, S., Liu, Y., & Sun, Y. (2023). Short and medium-chain chlorinated paraffins in indoor dust from a multistory residential building in Beijing, China: Vertical distribution and potential health risks. *Science of the Total Environment*, 861, 160642.
- [4] Viljanen, A., Lähtinen, K., Kanninen, V., & Toppinen, A. (2023). A tale of five cities: The role of municipalities in the market diffusion of wooden residential multistory

- construction and retrofits. *Forest Policy and Economics*, 153, 102991.
- [5] Alhuwayil, W. K., Almaziad, F. A., & Mujeebu, M. A. (2023). Energy performance of passive shading and thermal insulation in multistory hotel building under different outdoor climates and geographic locations. *Case Studies in Thermal Engineering*, 45, 102940.
- [6] Borelli, D., Cavalletti, A., Cavalletti, P., Peshku, J., & Tagliafico, L. A. (2024). A methodology to evaluate the optimal insulation thickness for heating and cooling needs in different climatic zones for buildings made of reinforced concrete with cavity walls. *Heliyon*, 10(10).
- [7] Wu, Y., Liu, Y., Li, A., Fu, J., Zhang, R., Lu, S., & Lu, J. (2024). Parameter analysis of a novel bilinear hysteretic rubber-shearing device for vertical seismic isolation of multistory frame structures. *Journal of Building Engineering*, 97, 110784.
- [8] El Zareef, M. A., Ghalla, M., Hu, J. W., & El-Demerdash, W. E. (2024). Damage detection of lightweight concrete dual systems reinforced with GFRP bars considering various building heights and earthquake intensities. *Case Studies in Construction Materials*, 20, e03191.
- [9] Rusek, J., Alibrandi, U., Slowik, L., & Chomacki, L. (2023). BNSL GOBNILP algorithm in application to damage intensity prognostic system to RC multistorey residential buildings subjected to negative impacts of the industrial environment of mines. *Journal of Building Engineering*, 80, 107885.
- [10] Srinath, G., Swain, S., & Gopikrishna, K. (2023). Seismic Capacity Estimation for Composite Multi-storeyed RC buildings. *Materials Today: Proceedings*, 93, 362-369.
- [11] M.K. Prajapati, "Structural behavior of building under the seismic load:- A brief review" *International journal for innovation engineering and management research (IJIEMR)*, volume-11, issue 01, ISSN NO: 2456-5083, January-2022.