

# The Development of a Basic Electricity Trainer

Achimi Abubakar, Akinleye Temitope Grace and Akinola Sebeel. A.

Department of Electrical / Electronics, College of Engineering, Federal University of Agriculture Abeokuta, Ogun State, Nigeria.

**Abstract**— *Technology never stops from innovating. Modernization goes with it rapidly. Thus education today needs to rise to the call of time through encouragement and equipping of laboratories with trainers which can be used to help students understand the basics in the world of digital electronics. This research is base on the development of a basic electricity trainer whose theory is based on ohm's law and Kirchhoff's law. Ohm's law explore the quantitative relationship between the current through a resistor and the potential difference (voltage) across the resistor. Kirchhoff's laws are rules used to completely solve a DC circuit.*

*We have experimentally tested Kirchhoff's Voltage Law and Kirchhoff's Current Law by measuring the sum of the voltage drops around several closed paths, and the sum of the currents at several nodes, in a resistive circuit made up of three resistors. A low resistance circuit was constructed using resistors  $1k\Omega$ ,  $2.2k\Omega$  and  $10k\Omega$  Kirchhoff's Current Law, which states that the algebraic sum of the currents at a node is zero, was found to be accurate to within 1% error. Kirchhoff's Voltage Law, which states that the algebraic sum of the voltage drops around a closed loop is zero, was found to be accurate to within 1% error when applied to the low resistance circuit. With these we conclude that Kirchhoff's Laws accurately predict the behavior of resistive circuits. The basic trainer itself is made up of four sections which are the metering section, the power supply section (comprises the variable 0-30V and fixed 5V and 9V), resistor array and components such diodes, zener diodes and thermistor. The trainer is completely recommended for performance Experiments in electrical laboratories.*

**Keywords**— *Electricity, registers, Kirchhoff's Voltage Law, Kirchhoff's Current Law.*

## I. INTRODUCTION

When beginning to explore the world of electricity and electronics, it is vital to start by understanding the basics of voltage, current, and resistance. These are the three basic building blocks required to manipulate and utilize electricity.

At first, these concepts can be difficult to understand because we cannot "see" them. One cannot see with the naked eye the energy flowing through a wire or the voltage of a battery sitting on a table. Even the lightning in the sky, while visible, is not truly the energy exchange happening from the clouds to the earth, but a reaction in the air to the energy passing through it.

In order to detect this energy transfer, we must use measurement tools such as multimeters, spectrum analyzers, and oscilloscopes to visualize what is happening with the charge in a system.

Ohm's Law for electrical resistance,  $V = IR$ , states the relationship between current, voltage, and electrical resistance. If R is constant, V is proportional to I.

However, the resistance of a device can't always be assumed to be a constant, you might recall that electrical resistance varies with temperature. Diodes are designed to conduct electricity in only one direction, and thermistors are designed to be especially sensitive to temperature.

The electrical circuit contains voltage sources (power supply) and components, such as the resistors, diodes etc. that are used in the laboratory. A point in the circuit where two or more components connect together is called a circuit node. A path from one node to another is known as a circuit branch. A closed path through the circuit that starts at a particular node and passes through a sequence of components before arriving back at the starting node without the path crossing itself is called a circuit loop. All circuits have at least two nodes and at least one loop. It is possible to have several loops in a circuit, and the various loops may partially overlap each other.

These basic trainer will give the basic understanding of voltage, current, and resistance (how the three relate to each other), diode characteristics and thermistor characteristics

### 1.1 OBJECTIVES

To develop a basic Electricity Experimental trainer that can be used to carry out simple experiment to demonstrate the following specific objectives;

- a. To verify Ohm's law.
- b. To compare the potential vs. current behavior of a resistor
- c. To determine the equivalent resistance of combinations of resistors by current-voltage method.

- d. To demonstrate current and voltage divider rule.
- e. To determine KVL and KCL
- f. Determination of power and energy using resistance, current and voltage parameter

## II. BASIC OVERVIEW OF THE DEVELOPED ELECTRICITY TRAINER

The trainer is composed of some section, which can be regarded as standalone. For experiment to be performed on it, it needs the use of banana plugs. An AC source is supplied

to it from source but in the trainer is a power pack of rating 32.5V, 7A which converts the AC source to DC source of fixed voltages 5V, 9V and a variable voltage ranging from 0-30V.

The requirement of regulated DC power supplies differ widely among the various electrical and electronic devices. Figure 1 shows the generalized block diagram of the designed basic electricity trainer unit. Each block in the diagram represents a section of the circuit that carries out a specific function.

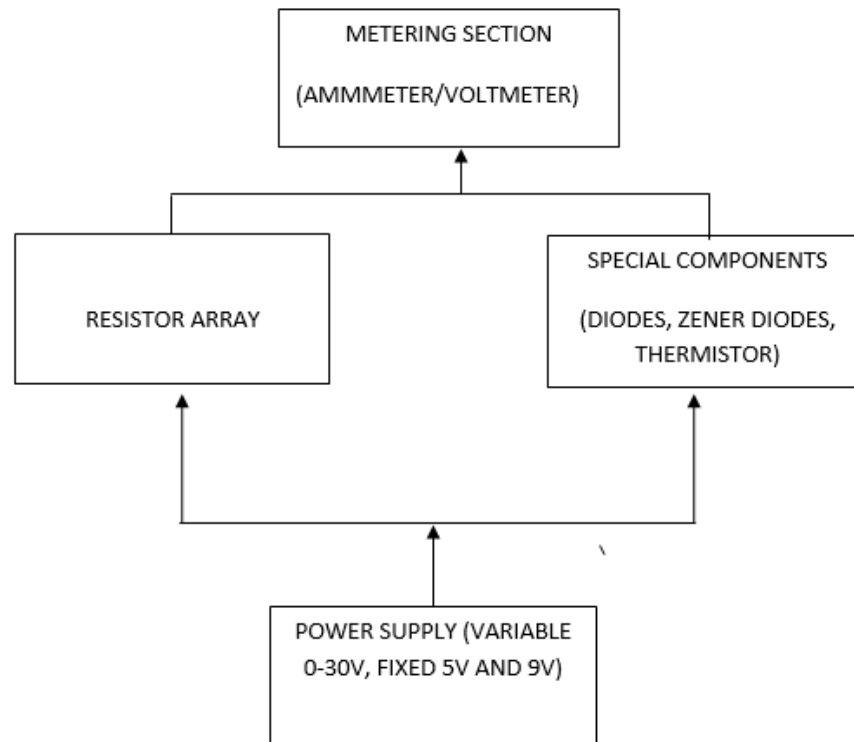

The basic and integral components of the block diagram in figure 2 above are briefly described below.

**2.1 Power supply:** The power pack initially takes the input supply from AC mains voltage of 220V and steps it down to a lower voltage level of variable 0-30V and fixed 5V and 9V respectively. However, after construction, the desired voltage range was obtained at the output.

**2.2 Resistor Array:** These comprises of resistor of various values, these gives the opportunity for desired resistor value for experiment to be chosen

**2.3 Metering section:** comprises the ammeter which reads values between 0-10mA and a voltmeter which reads values between 0-30V. Ammeters are connected in series so

that the current flows through them. The ideal ammeter has a resistance of zero so that it has no effect on the circuit while Voltmeters are connected in parallel to resistive elements in the circuit so that they measure the potential difference across (on each side of) the element.

**2.4 Special component:** These comprises of a diode and a thermistor.

**2.5 Fuses:** Fuses are over-current protection devices, therefore protecting the circuit and other components from damage due to excessive current.

**2.6 The mains:** The on/off button for start and termination of experiment

III. DESIGN AND METHODOLOGY

# BASIC ELECTRICITY EXPERIMENTAL TRAINER

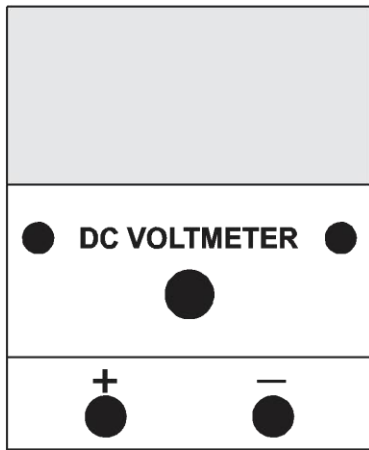

ON/OFF SWITCH

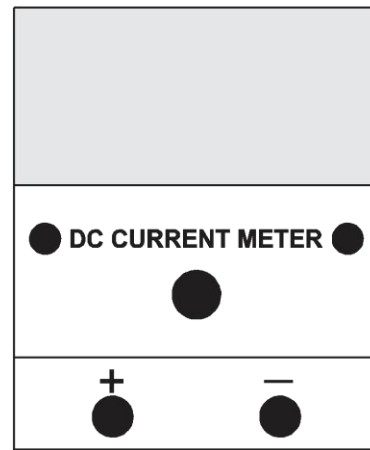

ON/OFF SWITCH

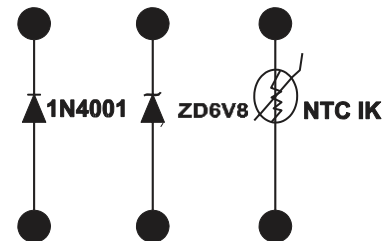
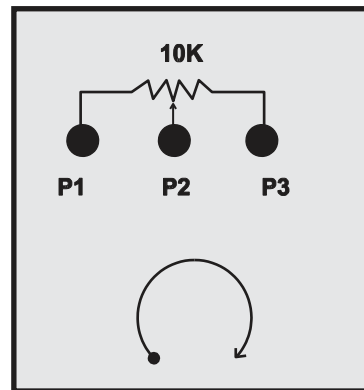
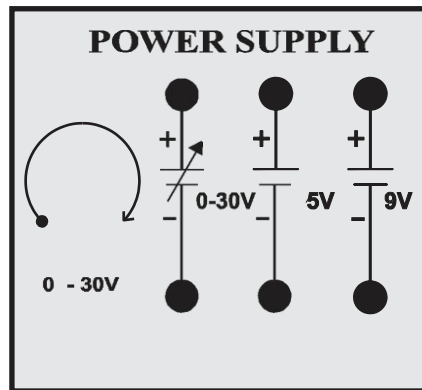
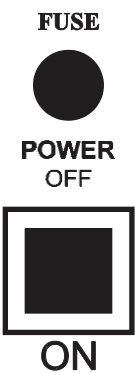

3.1 DESIGN CALCULATION

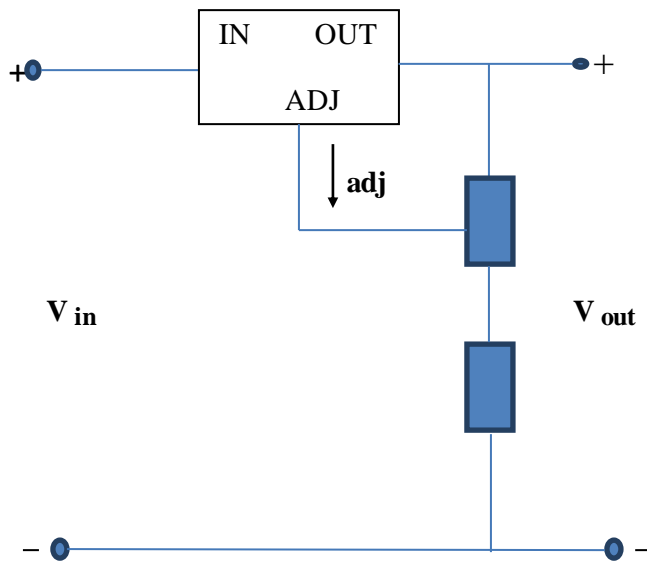

$$V_{out} = 1.25 \left( 1 + \frac{R_2}{R_1} \right) + (I_{adj} R_2)$$

but  $I_{ad}R_2 \ll 1$

$$V_{out} = 1.25 \left( 1 + \frac{R_2}{R_1} \right)$$

$$V_{in} = 30V$$

$$R_1 = 220\Omega$$

$$R_2 = 0 - 5k\Omega$$

$$V_{in} = 30V$$

$$R_1 = 470\Omega$$

$$R_2 = 0 - 10k\Omega$$

3.2 METHODOLOGY

3.2.1 Theory

The fundamental relationship among the three important electrical quantities *current*, *voltage*, and *resistance* was discovered by Georg Simon Ohm. The relationship and the unit of electrical resistance were both named for him to commemorate this contribution to physics. One statement of

Ohm's law is that the current (I) through a resistor is proportional to the potential difference (V) across the resistor. Ohm's law is normally written as

$$V=IR \quad (V) \quad (1)$$

Where R is the resistance of the resistor in Ohm ( $\Omega$ ) when potential difference (V) is in Volt and current (I) in Ampere (A). Resistance is a measure of how difficult to flow current through the device.

This experiment trainer will verify Ohm's law in several different circuits using banana plugs to make connections. Any device that obeys Ohm's law showing linear relationship of V and I is called Ohmic device, otherwise non-ohmic device.

Ohm's law is used to determine the equivalent resistance of resistors connected in different combinations. Fig. 3a shows the resistors connected in series and Fig. 3b shows the resistors connected in parallel.



Fig.3a: Resistors in Series

Equivalent resistance ( $R_{eq}$ ) in series combination of resistors is given by

$$R_{eq} = R_1 + R_2 + R_3 + \dots + R_n \quad (2)$$

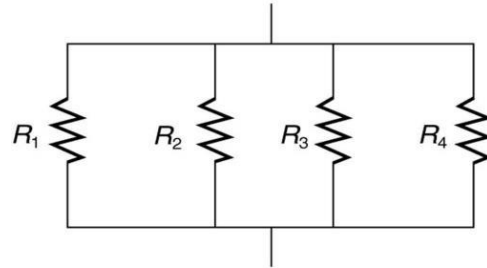
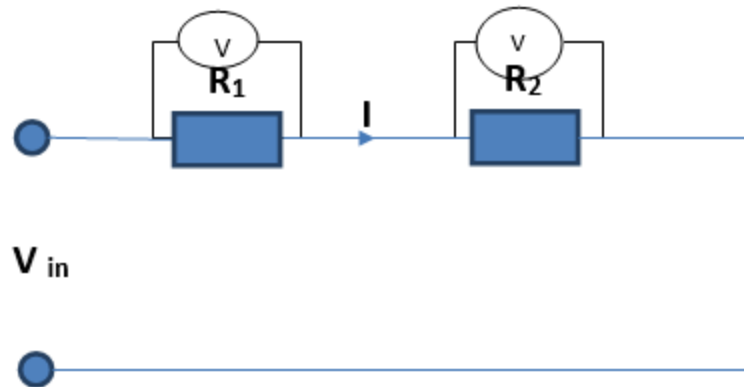

Fig 3.2: Resistors in Parallel

and the equivalent resistance ( $R_{eq}$ ) in parallel combination of resistors is given by

$$\frac{1}{R_{eq}} = \frac{1}{R_1} + \frac{1}{R_2} + \frac{1}{R_3} + \dots + \frac{1}{R_n} \quad (3)$$

### 3.3 VOLTAGE DIVIDER AND CURRENT DIVIDER RULE



$$I = \frac{V}{R_1 + R_2}$$

$$V_1 = V_{in} \left( \frac{R_2}{R_1 + R_2} \right)$$

$$V_2 = V_{in} \left( \frac{R_1}{R_1 + R_2} \right)$$

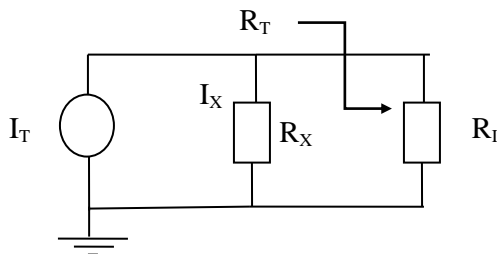

$$I_X = \frac{R_1}{R_1 + R_X} I_T$$

### 3.4 Kirchhoff's Voltage Law

Kirchhoff's Voltage Law (KVL) states that the sum of all voltages in a closed loop must be zero. A closed loop is a path in a circuit that doesn't contain any other closed loops. Loops 1 and 2 in Figure 3.4 are examples of closed loops.

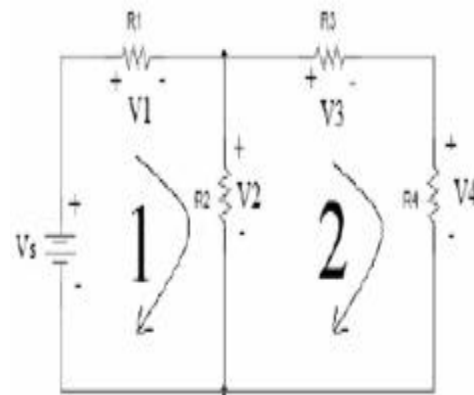

Fig.3.4: An example of KVL circuit

The perimeter of the circuit is also a closed loop, but since it includes loops 1 and 2 it would be repetitive to include a KVL equation for it. If loop 1 is followed clockwise the KVL equation is

$$V_1 + V_2 + V_3 = 0 \quad (4)$$

This equation holds true only if the passive sign convention is satisfied. In the case of KVL the passive sign convention states that when a positive node is encountered while following a loop the voltage across the element is positive. If a negative node is encountered the corresponding element

voltage is negative. In order to simplify the KVL equations, the polarities should be assigned to satisfy the passive sign convention whenever possible.

**3.5 Kirchhoff’s Current Law**

Kirchhoff’s Current Law (KCL) deals with the currents flowing into and out of a given node. KCL states that the sum of all currents at a node must equal zero. This is illustrated in Figure 3.4

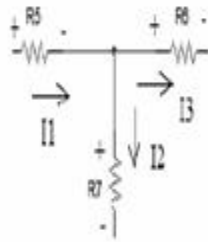

The equation obtained by KCL for the node shown in Fig. 3.4 is

$$I_1 - I_2 - I_3 = 0 \tag{5}$$

In the case of KCL the passive sign convention deals with the direction of currents with respect to the node. Currents entering the node must have opposite signs as those exiting the node. The passive sign convention with respect to KVL can also be applied to KCL. On many schematics the polarities of resistors are already assigned, so the directions of the currents should be assigned such that the current is entering the positive terminal. This will simplify later calculations.

**3.6 Experimental Test and Results**

The circuit was constructed on an adaptable board as described above. 5volts from the power supply was applied to the circuit. The voltages across and currents through each of the resistors was then measured and recorded in Table 3.1.

Nominal Resistance(k Ω)	Measured Resistance(k Ω)	Measured voltage(V)	Measured current(mA)
1	0.994	0.871	0.87
2.2	2.193	1.803	0.81
10	9.85	2.621	0.25

The measured voltage values were inserted into (4) to verify KVL.

$$0.871 + 1.803 + 2.621 = 5V \tag{6}$$

The measured currents were inserted into (5) to verify KCL at node B.

$$0.8 - 0.7 - 0.15 = 0$$

(7)

There is no expected error when KVL and KCL are performed on the results because the expected value is zero. Ohm’s law was used to calculate the resistance values using the values of the current through and voltage across each. A percent error analysis was then performed between the measured values and the Ohm’s law values. A sample calculation from the analysis is shown in below.

$$\%error = \frac{\text{measured value} - \text{calculated value}}{\text{measured value}} \times 100\%$$

$$\%error = \frac{2.193 - 2.23}{2.193} \times 100\% = 1.6871\%$$

These errors would ultimately be used to determine the validity of Ohm’s law. The calculated resistances as well as the errors are given in Table 3.2.

Resistor	Measured Value (Ωk)	Calculated Value (Ω)	% Error
R <sub>1</sub>	2.193	2.23	1.66%
R <sub>2</sub>	9.85	10.5	6.19%
R <sub>3</sub>	0.994	1.08	7.94%

**IV. DISCUSSION**

The experiment performed verified KCL. This was shown as found that the sum of the two currents exiting the node to be equal to the current entering the node. The experimental results of the KCL test were not so close. There was less than two percent error between the measured and calculated I. This error is acceptable in stating that KCL is true. The simulated KVL test was not as expected. Equation didn’t produced zero volts. However the equation added up to voltage small enough to be negligible in stating that KVL is valid. As with the KCL tests, the experimental KVL results in (6) did not meet the predicted values. Both of the equations produced values within one value away from zero. This is a large discrepancy, but it is still small enough to conclude that KVL and KCL is valid.

All of the percent errors for the calculated versus measured resistance were less than eight percent. The errors appeared to increase as the resistor number increased (i.e. R<sub>1</sub>, R<sub>2</sub> etc.).

This was probably due to error accumulation in the calculations. Slight errors such as rounding in intermediate calculation steps would account for the increase. Another possible source of error was in the values of the resistors chosen. The resistors all had values in the kilo-ohm range. Such large resistance values would make it difficult to

accurately measure the small currents passing through them. This would account for part of the discrepancy. The errors were all fairly small which lead to the conclusion that Ohm's law is indeed valid.

A major source of error that applies to all three cases was the measuring process. If fingers were in contact with both leads of the multi-meter when taking resistance measurements the readings would be slightly off. This is because the meter would try to add the resistance of the body in the loop. The same type of problem could have occurred with the voltage and current measurements. If the connections were not fully made then the meter would have made inaccurate readings

**4.1 Basic Diode characteristics that would be observed with the use of Multimeter or Oscilloscope**

A diode is a semiconductor device, which conduct the current in one direction only. It has two terminals, the cathode and anode. When the positive polarity is at the anode the diode is forward biased and is conducting. When the positive polarity is at the cathode, the diode is reverse biased and is not conducting. If the reverse biasing voltage is sufficiently large the diode is in reverse breakdown region and large current flows through it.

**4.1.1 Diode characteristics**

1) Voltage drop across the diode when reverse biased is 1nA(10<sup>-9</sup>A)

2) Voltage drop across the diode when forward biased is 0.6-0.7V

As the temperature increases the voltage of the knee decreases by 2mV/K

The reverse current doubles for each 10<sup>0</sup>K increase in temperature

**4.1.2 Zener Diodes**

These diodes are intended to operate in breakdown region. If breakdown voltage > 6V avalanche breakdown occurs, if breakdown voltage is < 6V tunneling mechanism of breakdown occurs.

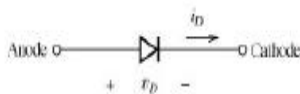
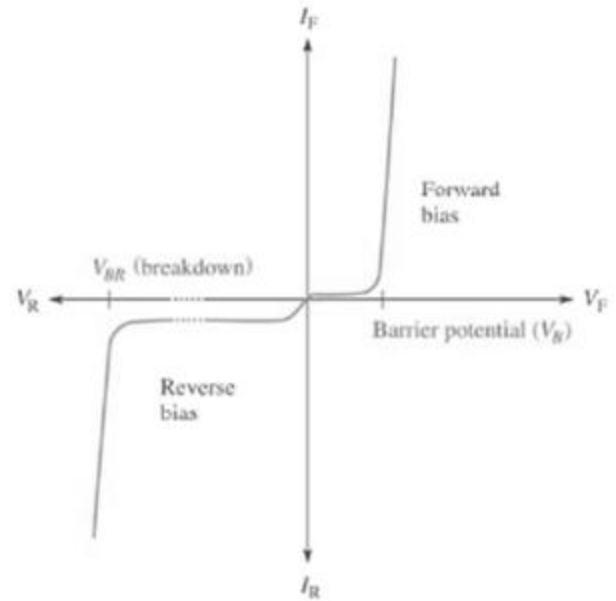

Fig.4.1: a Circuit symbol



b) Volt-ampere characteristics  
Fig 4.1 Semiconductor diode

**4.2 Basic Thermistor characteristics that would be observed if connected to a Multimeter**

Thermistors, like RTDs, are thermally sensitive semiconductors whose resistance varies with temperature. Thermistors are manufactured from metal oxide semiconductor material encapsulated in a glass or epoxy bead. Also, thermistors typically have much higher nominal resistance values than RTDs (anywhere from 2,000 to 10,000 Ω) and can be used for lower currents.

**4.2.1 Theory**

In order to measure temperature with the thermistor, you only need to measure the resistance of the thermistor, and then substitute the resistance value in the following equation

$$T = \frac{1}{a + b(\ln R) + c(\ln R)^3}$$

Where: T : Calculated temperature in (K)

R: Measured resistance in (Ω)

a, b and c are Steinhart-Hart Constants that have the following values

$$a = 1.2407635 * 10^{-3}$$

$$b = 2.3612017 * 10^{-4}$$

$$c = 8.97975 * 10^{-8}$$

From the above equation you will get the temperature in Kelvin. The value of a, b and c differs from one type of to another.

**4.2.2 Prevalent Characteristics**

1) Each sensor has a designated nominal resistance that varies proportionally with temperature according to a linearized approximation.

2) Thermistors have either a negative temperature coefficient (NTC) or a positive temperature coefficient (PTC). The first, more common, has a resistance that decreases with increasing temperature while the latter exhibits increased resistance with increasing temperature.

3) Thermistors typically have a very high sensitivity (~200  $\Omega/^\circ\text{C}$ ), making them extremely responsive to changes in temperature. Though they exhibit a fast response rate.

4) Thermistors are limited for use up to the 300  $^\circ\text{C}$  temperature range. This, along with their high nominal resistance, helps to provide precise measurements in lower-temperature applications.

## V. CONCLUSION

Ohm's law, KVL and KCL are three of the most basic techniques for the analysis of linear circuits. The purpose of the development of these trainer is to assist students in proving these laws valid. A circuit was provided with three unknown voltages and three unknown currents. Then the circuit was built on a board. The voltage and current values were measured and placed into KVL and KCL equations to determine whether they turned out as predicted. These measured values were then used in the Ohm's law equation to find resistance.

The calculated and measured values were then compared to the expected results from the theories. All of the discrepancies between tested and expected values were small, therefore all three of the laws could be considered valid. The electrical activity of the resistors observed indicates that current passing through resistors with exhibits ohmic behaviors. The reason for linear characteristics when plotted on a graph.

The Diodes, Zener diodes and Thermistor are present so that their electrical characteristics can be observed with the use of multimeter or Oscilloscope in an experiment.

## 5.1 RECOMMENDATION

This is an immense contribution to the body of academics and so it is recommended to be used in laboratories where fundamental knowledge of electrical and electronics is to be taught.

## REFERENCES

[1] Adejumobi I. A., Olanipekun A.J., Adebisi O.I., Adetomi A.A. (2012). Development of a Multi AC/DC

power supply system for domestic and laboratory use. IJRRAS, Vol 2 (126 – 132).

- [2] Brad Peirson, (2005). Verification of Ohm's Law, Kirchoff's Voltage Law and Kirchoff's Current Law.
- [3] Diodes and Diode Circuits **TLT-8016 Basic Analog Circuits** (2006). Chapter 3. Tampere University of Technology.
- [4] Germanna Community college (2017). Ohm's and Kirchoff's law. Academic center for excellence.
- [5] <https://docplayer.net/21087415-3-diodes-and-diode-circuits-3-diodes-and-diode-circuits-tlt-8016-basic-analog-circuits-2005-2006-1.html>
- [6] Ohm's and kirchoff's circuit law [http://www.montana.edu/rmaher/ee101/ecebot/f107\\_notes/ee\\_101\\_lab02\\_kirchoff\\_F07.pdf](http://www.montana.edu/rmaher/ee101/ecebot/f107_notes/ee_101_lab02_kirchoff_F07.pdf)
- [7] Ohm's law and DC circuits <https://www3.nd.edu/~hgberry/Fall2012/p31220%20Ohms%20Law.pdf>
- [8] Ohm's law <http://dephome.brooklyn.cuny.edu/physics/lab/phy2/newlabs/Ohms-law-ver-1a.pdf>
- [9] On the limits of Ohm's Law Abstract – SFU (2006). [www.sfu.ca/phys/233/materials/LaTeX\\_resources/sample\\_formal\\_report.pdf](http://www.sfu.ca/phys/233/materials/LaTeX_resources/sample_formal_report.pdf)
- [10] Thermistor characteristics, <http://engineering.ju.edu.jo/ar/Arabic/Laboratories/Thermistor%20characteristics.pdf>