

A Solar PV Array Based Multipurpose EV Charger

Haritha M¹, Tony Thomas², Induja S³

¹PG Scholar, Department of Electrical and Electronics Engineering, GEC Idukki, Kerala, India

^{2,3}Assistant Professor, Department of Electrical and Electronics Engineering, GEC Idukki, Kerala, India

Received: 19 Jul 2021,

Received in revised form: 30 Aug 2021,

Accepted: 09 Sep 2021,

Available online: 14 Sep 2021

©2021 The Author(s). Published by AI
Publication. This is an open access article
under the CC BY license
(<https://creativecommons.org/licenses/by/4.0/>).

Keywords— Bidirectional dc-dc converter, Electric vehicle battery, Solar photovoltaic array, V2G, V2H.

Abstract— This paper describes an electric vehicle battery charging mechanism with solar PV array based multipurpose EV charger. Multipurpose EV charger consists of two converters, one is bidirectional DC-DC converter (BDDC) and other is voltage source converter (VSC). The operation of the EV battery charger is managed in such a way that it is either supplied by PV power or by a grid. Vehicle to the grid (V2G) operation is implemented for improving the stability of the grid during peak load hours and vehicle to home (V2H) is also enabled during islanding mode of operation. For regulating the DC-link voltage from the bidirectional battery converter, a PI control mechanism was provided to this system. The bidirectional DC-DC converter works in buck mode during the charging time of the EV battery and works in boost mode during the discharging time. The charging system operates as an active power filter using voltage source converter (VSC) and the total harmonic distortion (THD) of the grid current lies within the IEEE 519 standard. The various modes of operations are simulated and tested by using MATLAB/Simulink.

I. INTRODUCTION

Nowadays global warming problems and gasoline prices are boosting day by day. An electric vehicle attracts more attention because of its clean and environmental friendly features. This paper is a solution to meet the basic transportation needs in a greener way. The electric vehicles readied with an energy storage device can be connected to the grid when they are not in use so that a high scale of energy for grid power can be supplied. The integration of energy storage along with distributed energy sources improves the power quality of the grid also. An electric vehicle offer low carbon emission, compression of greenhouse gases and is eco-friendly in nature. The main challenges for an electric vehicle charging mechanism is the lifetime of the battery and charging time. The anxiety among people dealing with the technology of EV is the limited driving range, long charging time and economical aspects. Long charging time would affect the performance of fast charging strategies and related new devices are

developed to improve the charging time. Before moving towards EV technology the infrastructure should be arranged for reliable operation of EVs which includes charging station and EV service station [1]. The charging station plays a key role in EV technology and it should be easily accessible. The solar PV array based charging station location should be in a solar irradiance available area. The charging time of EV should be reduced and precise battery management solutions should be executed for the long driving range [2], [7]. Solar energy conversion system is a renewable energy source that is available in generous and free of cost worldwide. Solar PV is used to transform solar energy into electrical energy. Solar PV cells have nonlinear characteristics and their efficiency is low. The DC power output of the solar PV cell varies with solar irradiation and ambient temperature. A solar PV array-based charging station is presented in this paper to prevent the overloading of the grid and also to minimize the operational cost of the charging station [3]. In this system, the boost converter is abolished and the solar PV

array is connected directly to the EV battery through a bidirectional converter. The voltage regulation for battery charging is done by the bidirectional converter connected to the EV battery. Therefore, this bidirectional multipurpose EV charger is a retrofit solution to the prevailing single-phase bi-directional charger with a modification in the control algorithm [4], [6]. The proposed charging system has the following unique features,

1-Solar PV array-based multi-purpose EV charger provide Vehicle to Grid (V2G), Vehicle to Home (V2H), and Grid to Vehicle (G2V) operation [5].

2-The proposed system will act as an active power filter for reducing the harmonics in the grid current.

3- The THD lies within the limits of the IEEE 519 standard during the power exchanging.

II. SYSTEM CONFIGURATION

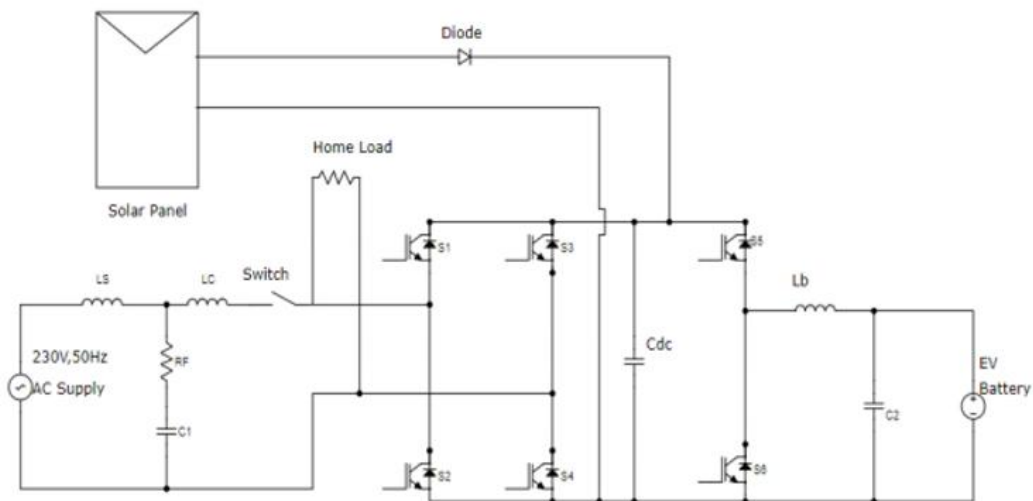

Fig. 1: Circuit diagram of the solar PV array based multipurpose EV charger

III. CONTROL MECHANISM

Two main control mechanism are mentioned here. This includes bidirectional DC-DC converter control and grid control mechanism. The need for this control mechanism is,

- 1) to balance the energy flow in the system
- 2) production of reference grid current for active power flow
- 3) charging/discharging current control of EV battery by controlling the bi-directional DC-DC converter

The energy balance in the system and harnessing of solar PV array power are attained by governing the DC bus

The described system topology is shown in Fig. 1. It consists of a single-phase bi-directional dc-dc converter that connects the EV battery directly on to the DC bus. A single phase VSC is provided for grid interconnection. Solar PV array-based EV charger is used for the multi-functionalities like EV charging from PV and grid, V2H operation and V2G operations. In the irradiance time of PV, the EV charging will occur and in the absence of PV irradiance, it can charge the EV from the grid. In the peak hour, it will discharge from the battery to the utility grid and also for home purposes. The EV battery is connected to the output of the bidirectional DC-DC converter (BDDC). This DC-DC converter in this charger accomplishes various tasks. While charging the EV battery, the DC-DC converter works in buck mode and operates in boost mode while discharging the EV battery. The proposed charger is connected to the grid through the coupling inductor (L_b). A coupling inductor is needed to eliminate the harmonics and to smoothen the grid current. This is the basic principle of the proposed system.

voltage. However, the active power control to the grid is attained by the grid current control [8].

i. Bidirectional DC-DC Converter Control

The purpose of the bidirectional dc-dc converter control is to regulate the DC bus voltage using voltage control as outer loop and current control as inner loop. The control mechanism is demonstrated in Fig. 2. The MPPT (Maximum Power Point Tracking) algorithm follows the reference DC bus voltage (V_{mpp} reference) during solar to EV charging. In the absence of solar PV irradiance, the DC link voltage is regulated at 360V by the bidirectional converter control. The DC bus voltage regulation is done by a proportional-integral (PI) controller. The error voltage of the DC link voltage on comparing with actual DC link

voltage is connected to a PI controller. The output of the voltage loop PI controller is then compared with the battery current. The error signal obtained is then connected to the current loop PI controller and then the switching pulses of the bidirectional dc-dc converter is generated by using a PWM generator. When the solar irradiance is low the reference of voltage loop is given as 360 V and when

during sufficient solar irradiance, V_{mpp} (voltage corresponding to maximum power) is given as reference. During V2G operation, I_{bref} is provided with the required current to be injected to the grid. During G2V operation, the reference voltage required for battery charging is provided as reference.

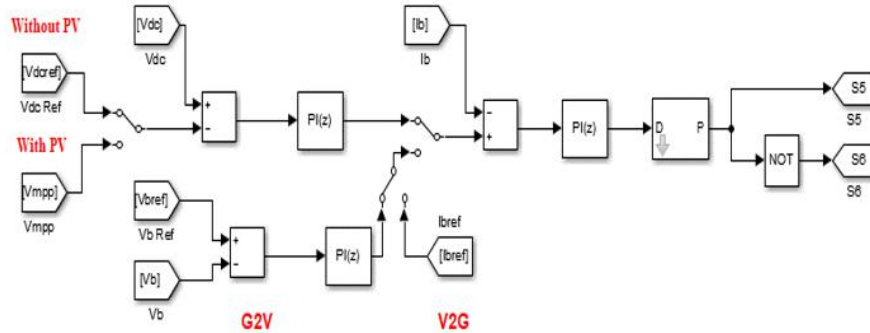

Fig. 2: Bidirectional DC-DC control of the system

ii. VSC Control

The VSC control as shown in Fig. 3 is used to control the grid current for controlling the power flow. The output of the outer voltage loop PI controller gives the magnitude of the reference grid current (I_{gref}) and using a hysteresis control, the grid current (I_g) is controlled. The proposed system will act as an active power filter with the THD

value of grid current less than 5%. S1, S2, S3, S4 indicates the switching pulses to the voltage source converter. The vehicle to grid control is done by using a PLL controller. It is a voltage driven oscillator that constantly adjusts to match the frequency of an input signal. The PLL controller also helps to generate, stabilize and modulate the signal from noise.

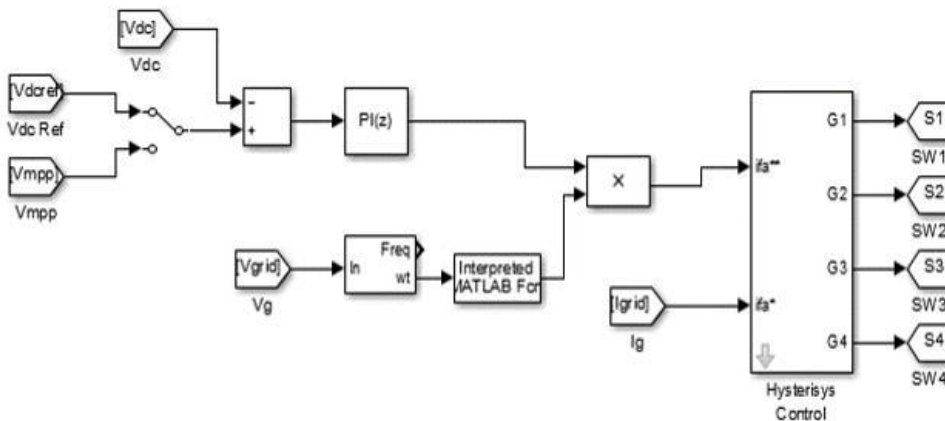

Fig. 3: VSC control of the system

iii. Operational Strategy based on SOC of Li-ion Battery

The energy management strategy of the proposed charger is shown in the Fig. 4. This strategy is based on the SoC of battery under different operating conditions. Here the measuring of SOC is set in between the lower limit of 0.2

and upper limit of 0.9, and the various modes of operation of the system are defined. When solar is not available and SoC of Li battery is less than lower limit of 0.2, load shedding is done.

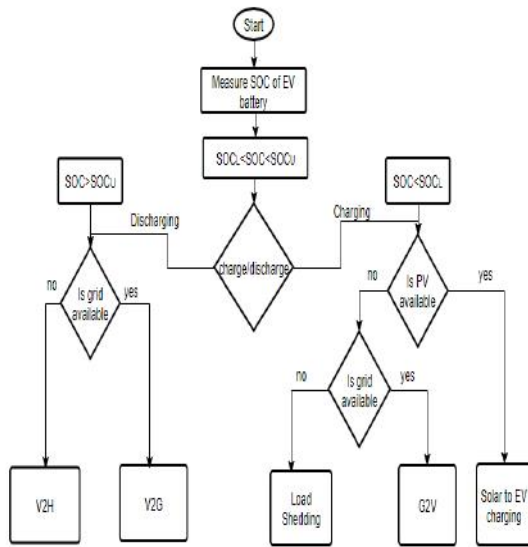

Fig. 4: Operational strategy

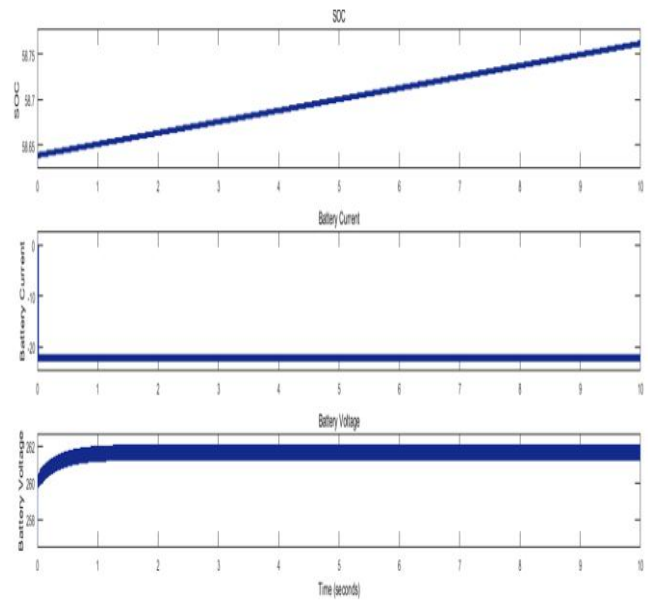

Fig. 5: Solar PV array to EV battery charging mode operation

IV. SIMULATION STUDIES AND RESULTS

Simulation of the proposed charger is done in MATLAB/Simulink. The system is tested for solar to EV charging, grid to EV battery charging and EV battery to home operation. The parameters used for simulation are shown in Table.1.

Table.1: Simulation Parameters

Components	Values
Switching frequency	50 kHz
EV battery	240 V, 10 Ah
Cdc	1100 μ F
C1, C2	1000 μ F
Lb	8 μ H
Lc	5 μ H
PV array Vm, Im	396 V, 21 A

A. Solar PV Array to EV Battery Charging Mode Operation

The EV battery is charged from solar panel and the resultant waveforms obtained are shown in Fig. 5. From this waveform we can analyze that, at the charging time the battery voltage increases, SoC of battery increases and battery current is negative. The EV battery is charged in constant current/constant voltage (CC/CV) mode.

B. Grid to EV Battery Charging Mode Operation

The grid to vehicle charging is illustrated in Fig. 6. During the vehicle charging, the battery voltage is increasing, SoC of battery is increasing and the battery current is negative.

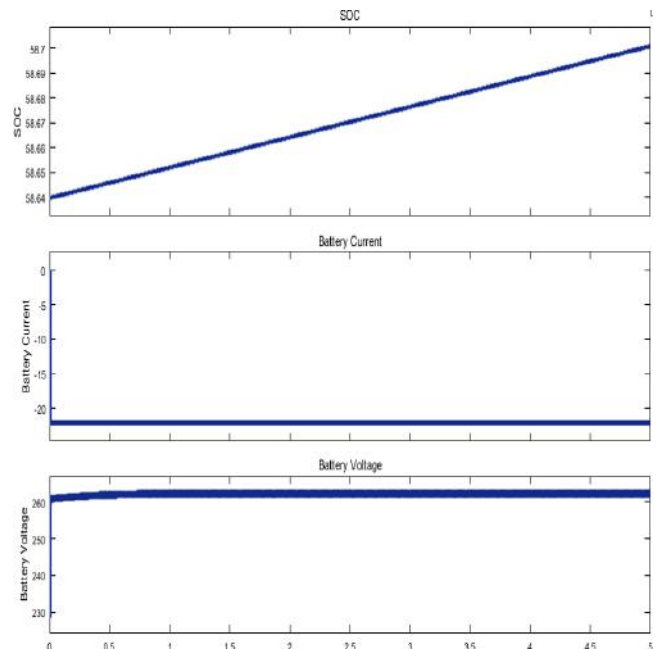

Fig. 6: Grid to vehicle (G2V) charging operation

C. EV Battery to Home Load Discharging Operation

The vehicle to home (V2H) operation is shown in Fig. 7. The load may be linear or non-linear. Here a linear load is used.

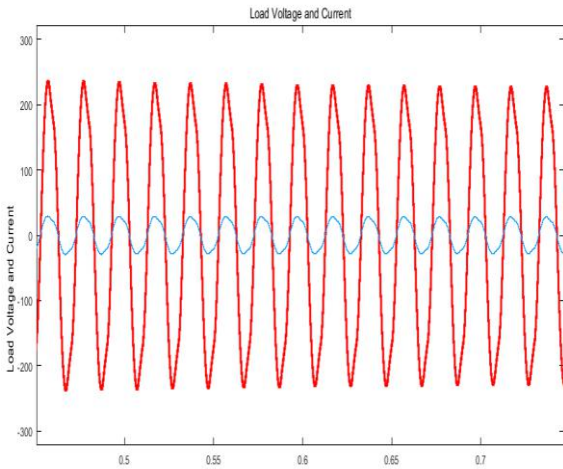

Fig. 7: Load voltage waveform of V2H operation

D. EV Battery to Grid Discharging Operation

In Fig. 8. shows the discharging mode of V2G operation. Here the battery voltage is decreasing, SoC of battery is decreasing and battery current is positive indicating discharging operation. Here it is showed that the EV charger is also controlled to operate as an active power filter for achieving the unity power factor (UPF) operation. The THD measurement waveform for grid current is shown in Fig. 10.

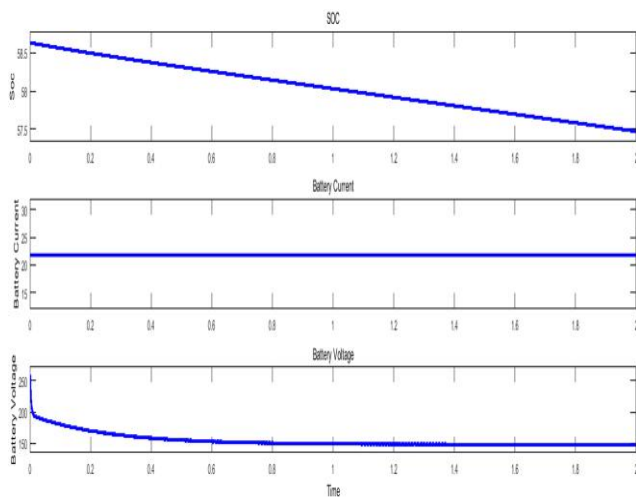

Fig. 8: Vehicle to grid (V2G) discharging operation

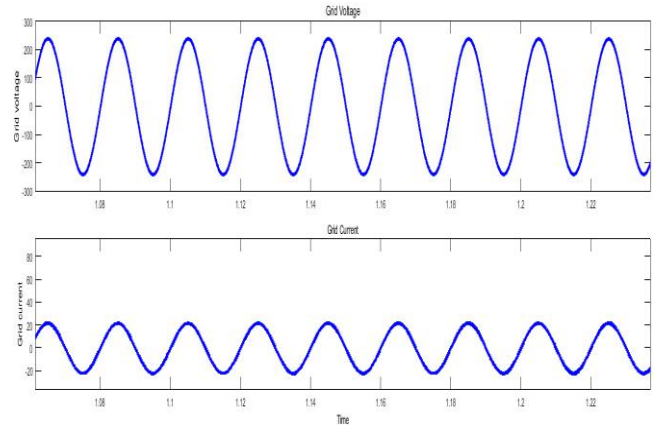

Fig. 9: Grid voltage and grid current waveform

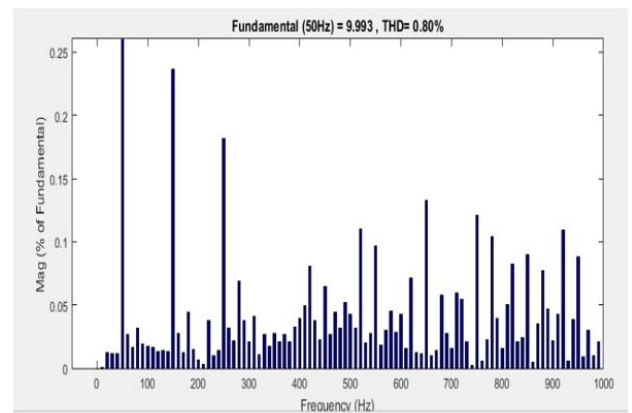

Fig. 10: THD measurement of grid current

V. CONCLUSION

In this paper, a solar PV array based multipurpose EV charger is presented. The mentioned system consists of an integrated charger with solar PV array, linear load and grid which has been implemented using IGBT switches and they are provided with suitable controlling methods. The solar PV charging is directly done here without using a boost converter that will reduce the circuit complexity. By using this proposed topology we can do both charging and discharging. So this charging system meets the requirements of household loads, EV and the utility. From these test results, it is observed that this charger is performing its specified task of EV charging, supplying local home loads and maintaining the power quality at the grid side. The charger is also controlled to operate as an active power filter for achieving the unity power factor (UPF) operation and total harmonic distortion (THD) of the grid current is within 5%.

REFERENCES

- [1] T. Ma and O. A. Mohammed, "Optimal Charging of Plug-in Electric Vehicles for a Car-Park Infrastructure," *IEEE Trans. Ind. Applicat.*, vol. 50, no. 4, pp. 2323-2330, July-Aug. 2014.
- [2] F. Marra, G. Y. Yang, C. Træholt and E. Larsen, "EV Charging Facilities and Their Application in LV Feeders With Photovoltaics," *IEEE Trans. Smart Grid*, vol. 4, no. 3, pp. 1533-1540, Sept. 2013.
- [3] N. Saxena, I. Hussain, B. Singh and A. L. Vyas, "Implementation of a Grid- Integrated PV-Battery System for Residential and Electrical Vehicle Applications," *IEEE Trans. Ind. Electron.*, vol. 65, no. 8, pp. 6592-6601, Aug. 2018.
- [4] Falin, J.: 'Designing DC/DC converters based on SEPIC topology', *Analog Appli. J.*, 2008, 4Q, pp. 18-23.
- [5] A. Verma, B. Singh, A. Chandra and K. Al-Haddad, "An Implementation of Solar PV Array Based Multifunctional EV Charger," in *IEEE Transpo.. Electrifi. Conf. and Expo (ITEC)*, Long Beach, CA, 2018, pp. 531-536.
- [6] H. Kikusato, K. Mori, S. Yoshizawa, Y. Fujimoto, H. Hiroshi, Y. Hayashi, A. Kawashima, S. Inagaki, T. Suzuki, "Electric Vehicle Charge- Discharge Management for Utilization of Photovoltaic by Coordination Between Home and Grid Energy Management Systems," *IEEE Trans. Smart Grid*, vol. 10, no. 3, pp. 3186-3197, May 2019.
- [7] M. Jafari, Z. Malekjamshidi, J. Zhu and M. Khooban, "Novel Predictive Fuzzy Logic-Based Energy Management System for Grid-connected and O- grid Operation of Residential Smart Micro-grids," *IEEE Journal of Emerging and Selected Topics in Power Electronics*, Early Access.
- [8] Z. Yi, W. Dong and A. H. Etemadi, "A Unified Control and Power Management Scheme for PV-Battery-Based Hybrid Microgrids for Both Grid-Connected and Islanded Modes," *IEEE Trans. Smart Grid*, vol. 9, no. 6, pp. 5975-5985, Nov. 2018.